

4

3



2

1

D

D

C

C

B

B

A

A

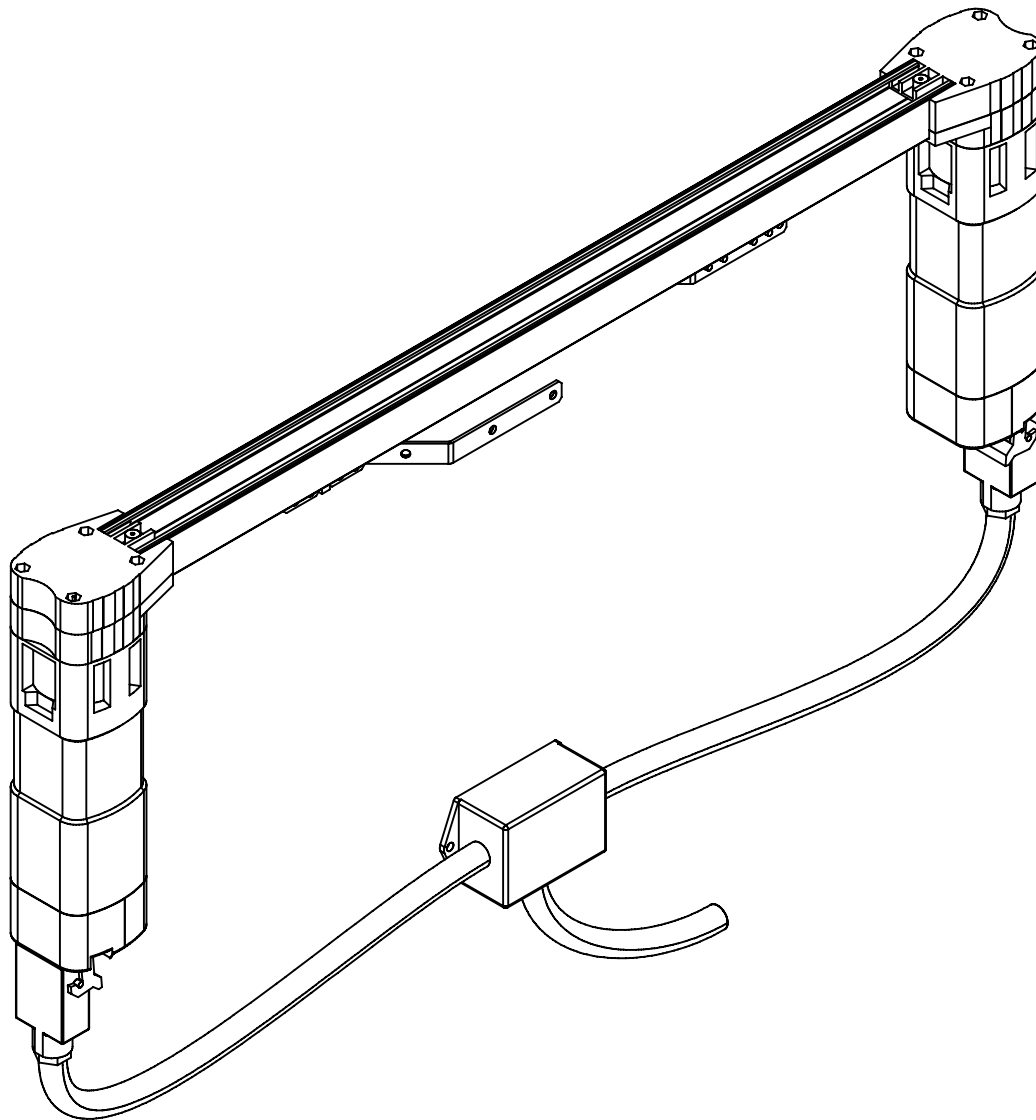

CONFIDENTIAL

All information disclosed in this document is proprietary to BTX Window Automation. Holder agrees to maintain it in confidence and must not replicate or reveal this information in any manner.

Project 5060

Dim Inches

TOLERANCES

.XX ± .015

.XXX ± .005

ANG ± 1°



BTX Window Automation
10763 Sanden Dr.
Dallas, Texas 75238
(214) 340-2800
(214) 343-2444 FAX

5060 30W Sofia™ Tandem

Size A Matl: Dwg No: sofia_S_30W_tndm Rev

By: G. Bennett

Date: 16-May-08

Scale: 1/4

Sheet 1 of 2

4

3



2

1

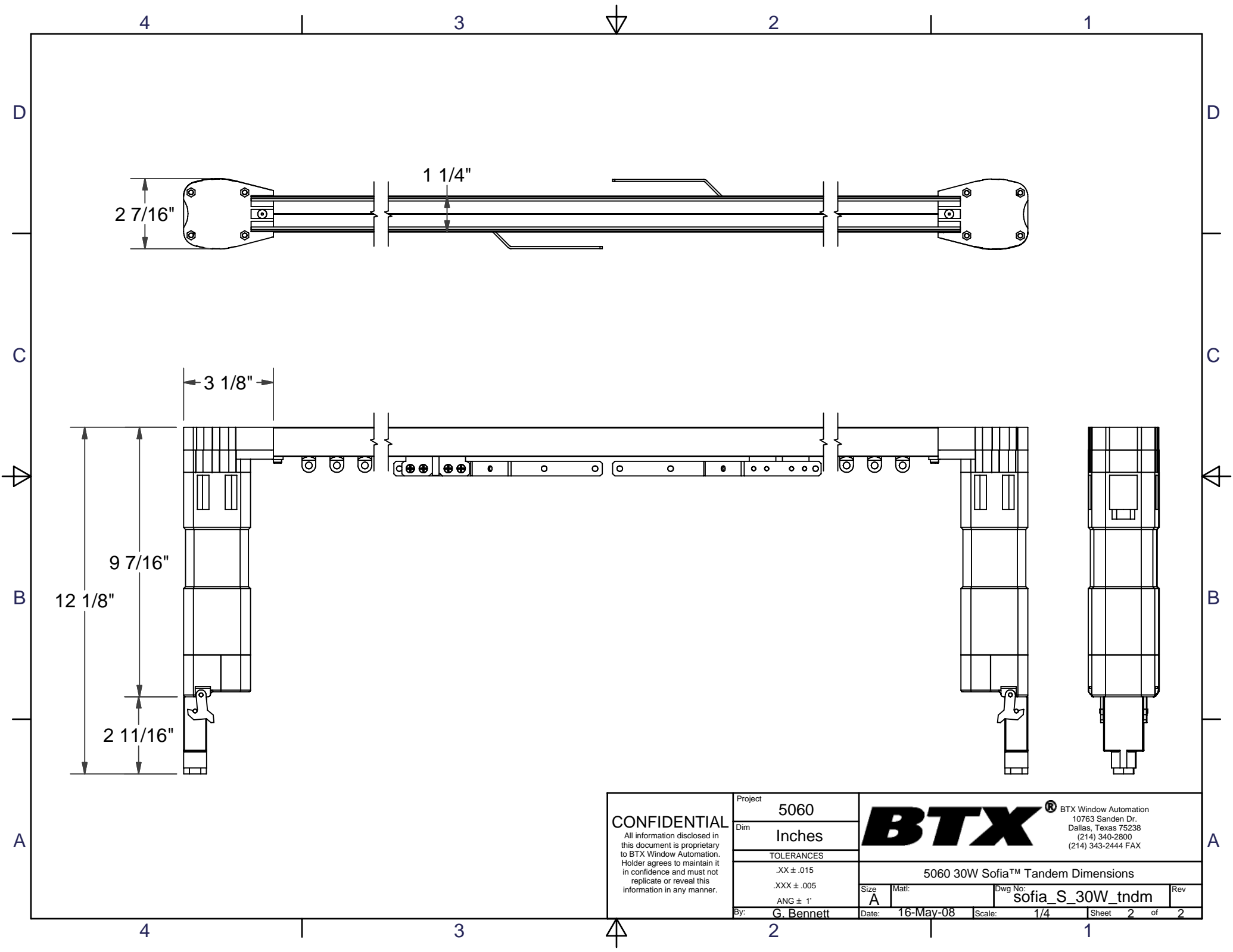

CONFIDENTIAL All information disclosed in this document is proprietary to BTX Window Automation. Holder agrees to maintain it in confidence and must not replicate or reveal this information in any manner.	Project	5060			 BTX Window Automation 10763 Sanden Dr. Dallas, Texas 75238 (214) 340-2800 (214) 343-2444 FAX
	Dim	Inches			
	TOLERANCES				
		.XX ± .015	5060 30W Sofia™ Tandem Dimensions		
	.XXX ± .005	Size	Matl:	Dwg No:	Rev
	ANG ± 1°	A		sofia_S_30W_tndm	
By:	G. Bennett	Date:	16-May-08	Scale:	1/4
		Sheet	2	of	2

4

3

2

1

D

D

C

C

B

B

A

A

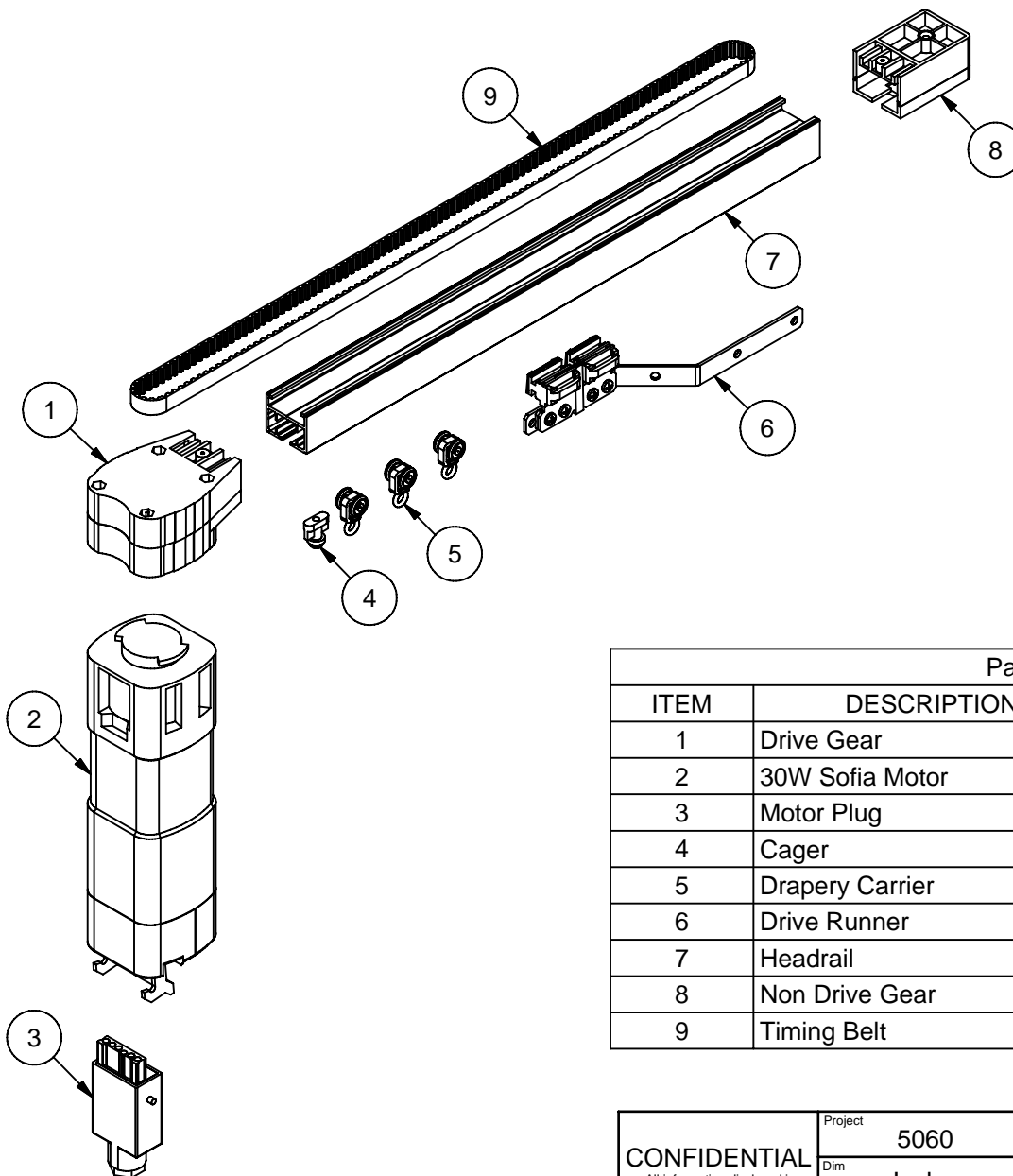

Parts List		
ITEM	DESCRIPTION	PART NUMBER
1	Drive Gear	256.7550
2	30W Sofia Motor	102.0300
3	Motor Plug	440.1141
4	Cager	240.8050
5	Drapery Carrier	240.1740
6	Drive Runner	266.4900
7	Headrail	310.5510
8	Non Drive Gear	256.1545
9	Timing Belt	290.2000

<p>CONFIDENTIAL</p> <p>All information disclosed in this document is proprietary to BTX Window Automation. Holder agrees to maintain it in confidence and must not replicate or reveal this information in any manner.</p>	Project	5060			BTX Window Automation 10763 Sanden Dr. Dallas, Texas 75238 (214) 340-2800 (214) 343-2444 FAX
	Dim	Inches			
	TOLERANCES			5060 30W Sofia™ Parts View	
		.XX ± .015			
	.XXX ± .005			Size	A
	ANG ± 1°			Matl:	
By:	G. Bennett	Date:	16-May-08	Scale:	1/4
				Dwg No:	sofia_S_30W
				Rev	
				Sheet	1 of 2

4

3

2

1

A

D

C

B

A

4

3



2

1

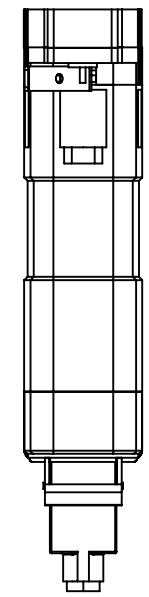
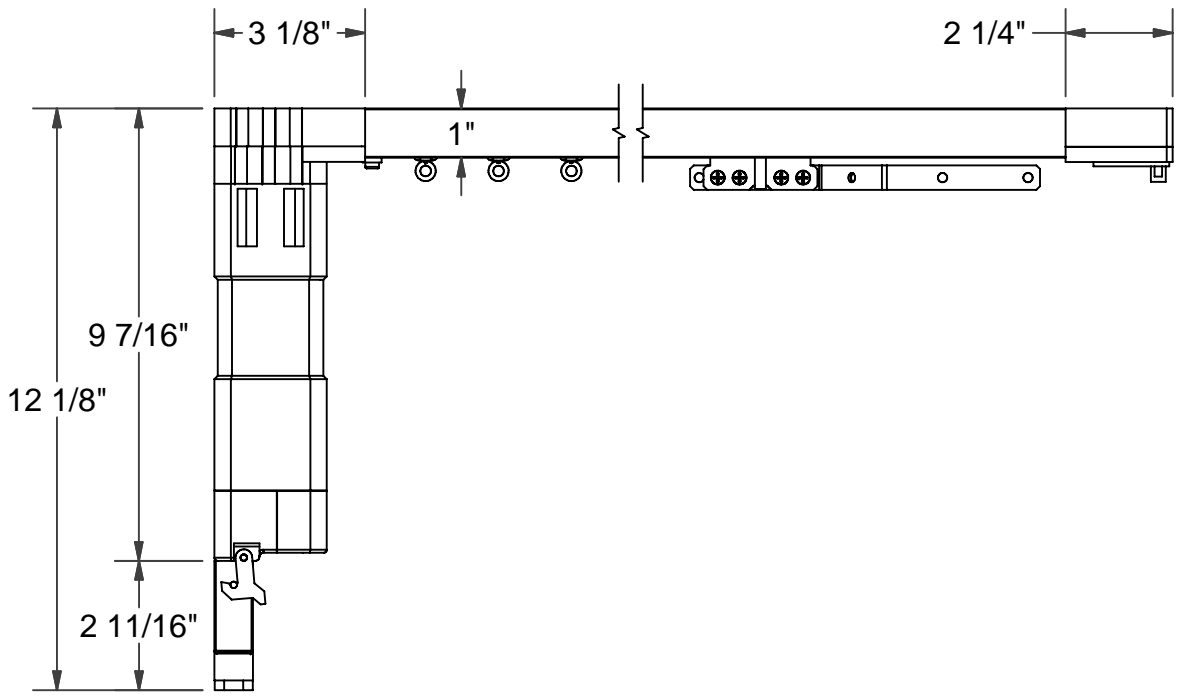
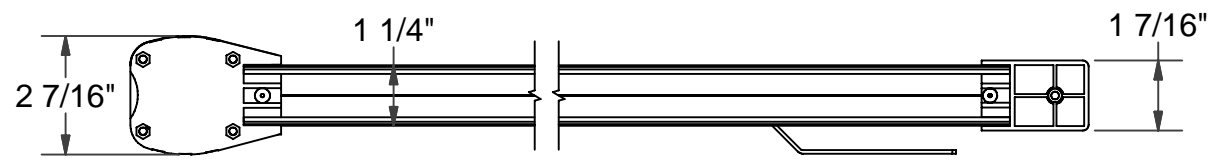

D

C

B

A

4

3



2

1

CONFIDENTIAL

All information disclosed in this document is proprietary to BTX Window Automation. Holder agrees to maintain it in confidence and must not replicate or reveal this information in any manner.

Project	5060
Dim	Inches
TOLERANCES	
.XX ± .015	
.XXX ± .005	
ANG ± 1°	
By:	G. Bennett

BTX® BTX Window Automation
 10763 Sanden Dr.
 Dallas, Texas 75238
 (214) 340-2800
 (214) 343-2444 FAX

5060 30W Sofia™ Dimensions

Size	A	Matl:		Dwg No:	sofia_S_30W	Rev	
Date:	16-May-08	Scale:	1/4	Sheet	2	of	2

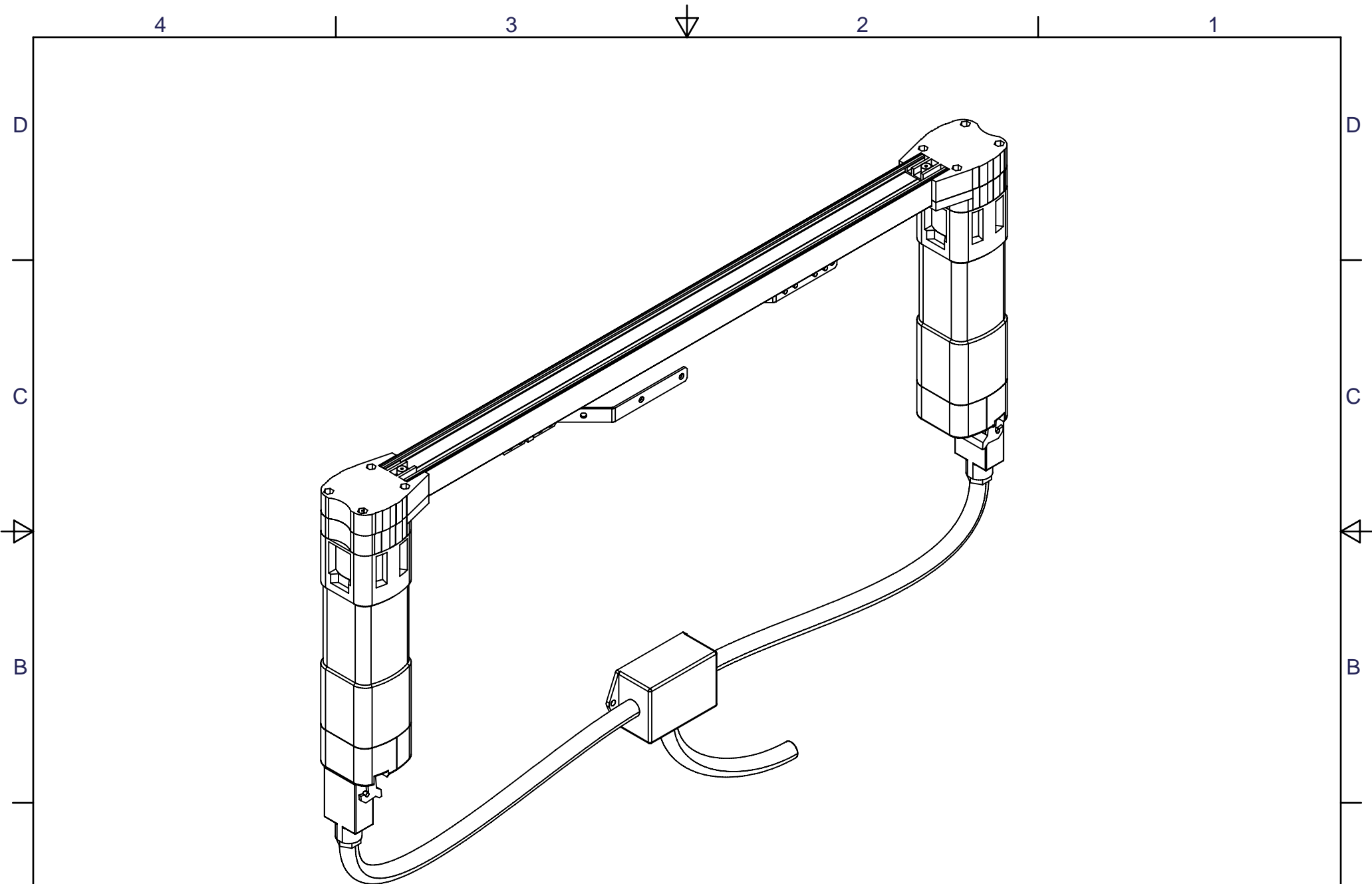

CONFIDENTIAL All information disclosed in this document is proprietary to BTX Window Automation. Holder agrees to maintain it in confidence and must not replicate or reveal this information in any manner.	Project	5060			 BTX Window Automation 10763 Sanden Dr. Dallas, Texas 75238 (214) 340-2800 (214) 343-2444 FAX				
	Dim	Inches							
	TOLERANCES								
		.XX ± .015	5060 45W Sofia™ Tandem Size A Matl: Dwg No: sofia_S_45W_tndm Rev						
		.XXX ± .005 ANG ± 1°							
By:	G. Bennett	Date:	16-May-08	Scale:	1/4	Sheet	1	of	2

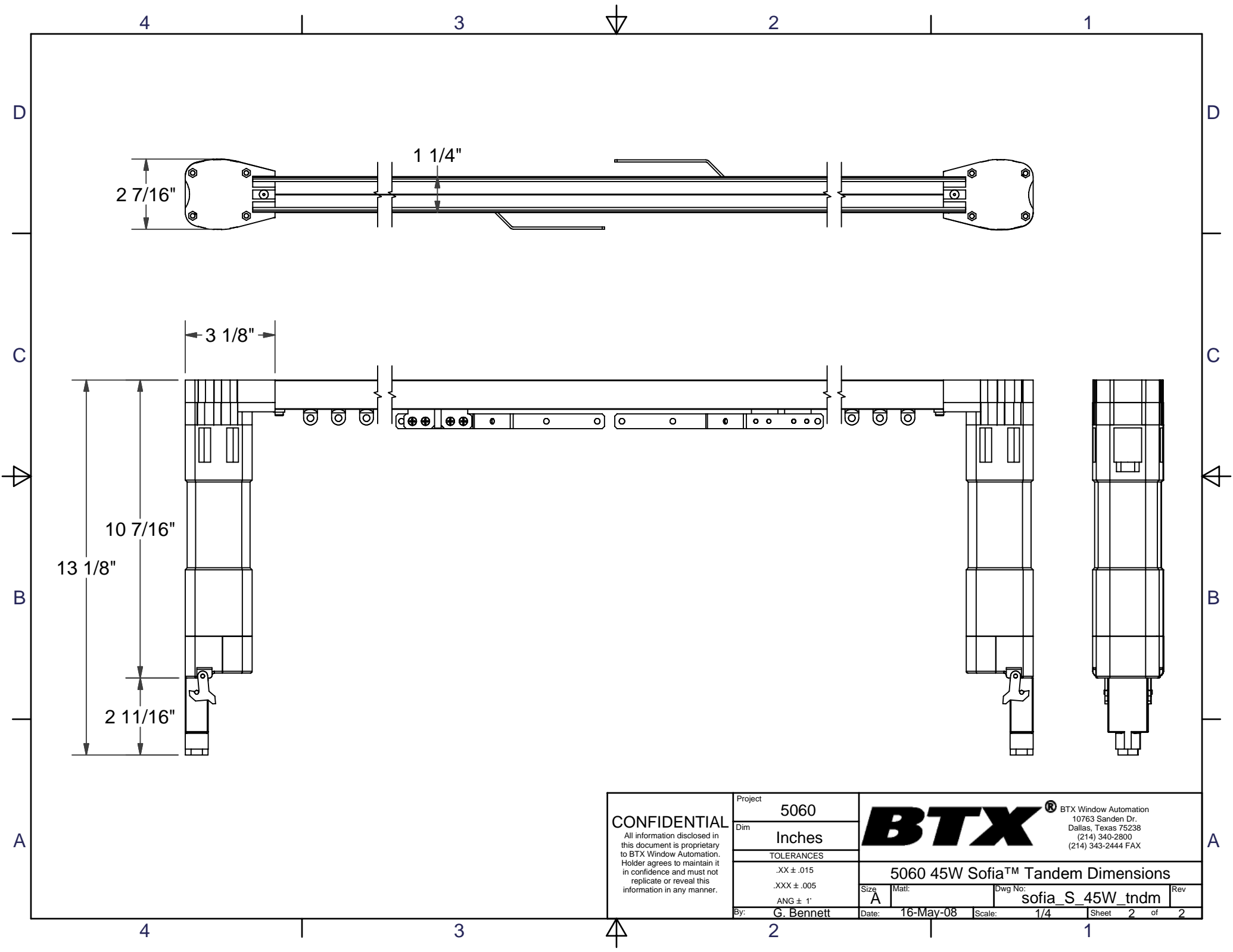

<p>CONFIDENTIAL</p> <p>All information disclosed in this document is proprietary to BTX Window Automation. Holder agrees to maintain it in confidence and must not replicate or reveal this information in any manner.</p>	Project	5060					
	Dim	Inches					
	TOLERANCES						
		.XX ± .015	<p>5060 45W Sofia™ Tandem Dimensions</p>				
		.XXX ± .005					
By:	G. Bennett	Date:	16-May-08	Scale:	1/4	Sheet	2 of 2

BTX® BTX Window Automation
 10763 Sanden Dr.
 Dallas, Texas 75238
 (214) 340-2800
 (214) 343-2444 FAX

Dwg No: **sofia_S_45W_tndm** Rev

4

3



2

1

D

D

C

C

B

B

A

A

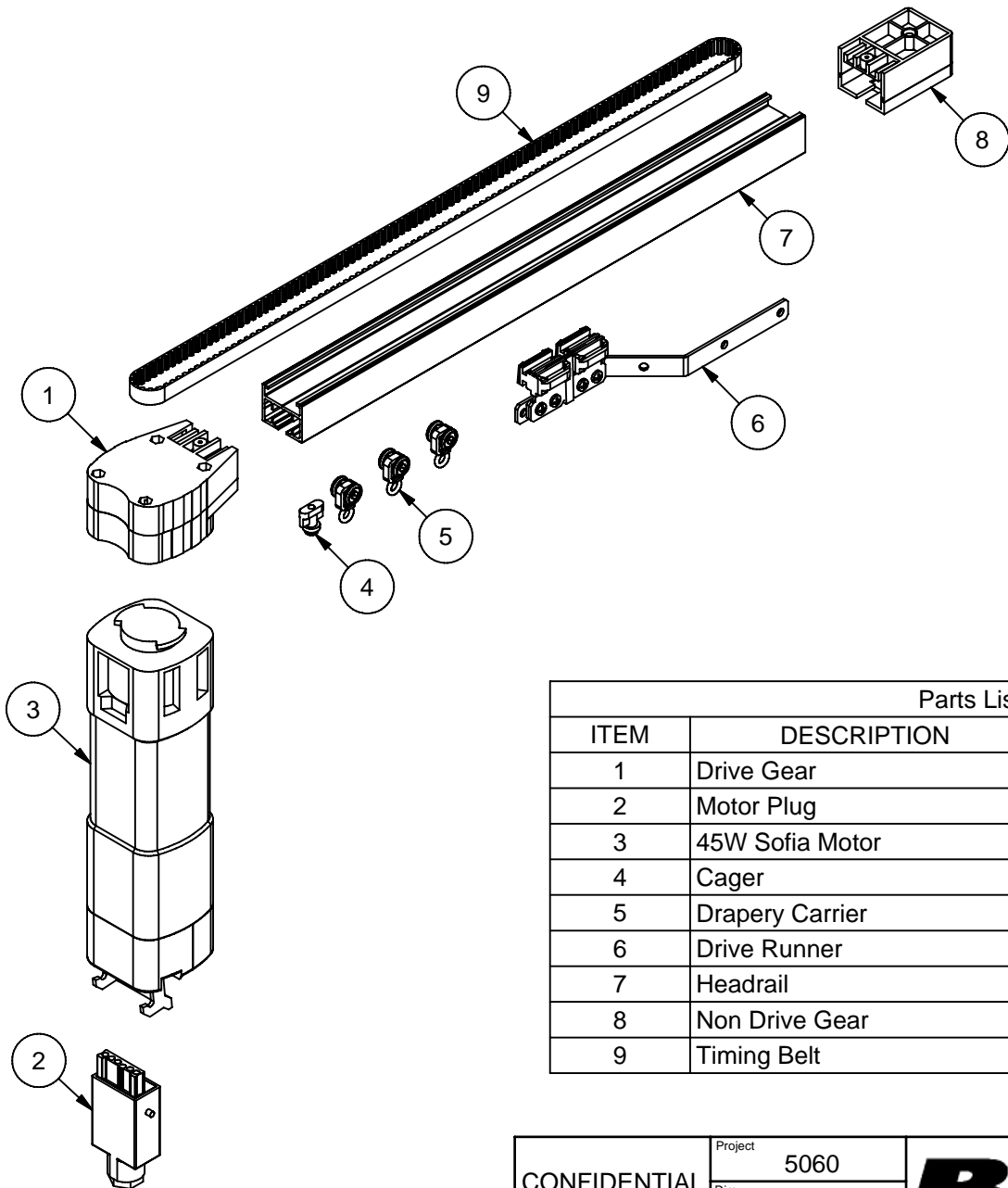

Parts List		
ITEM	DESCRIPTION	PART NUMBER
1	Drive Gear	256.7550
2	Motor Plug	440.1141
3	45W Sofia Motor	102.0400
4	Cager	240.8050
5	Drapery Carrier	240.1740
6	Drive Runner	266.4900
7	Headrail	310.5510
8	Non Drive Gear	256.1545
9	Timing Belt	290.2000

CONFIDENTIAL All information disclosed in this document is proprietary to BTX Window Automation. Holder agrees to maintain it in confidence and must not replicate or reveal this information in any manner.	Project	5060		BTX Window Automation 10763 Sanden Dr. Dallas, Texas 75238 (214) 340-2800 (214) 343-2444 FAX					
	Dim	Inches							
	TOLERANCES			5060 45W Sofia™ Parts View					
	Size	A	Matl:		Dwg No: sofia_S_45W				
By:	G. Bennett	Date:	16-May-08	Scale:	1/4	Sheet	1	of	2

4

3



2

1

D

C

B

A

4

3

2

1

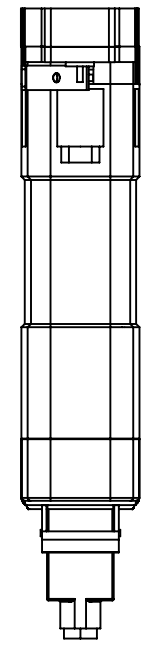
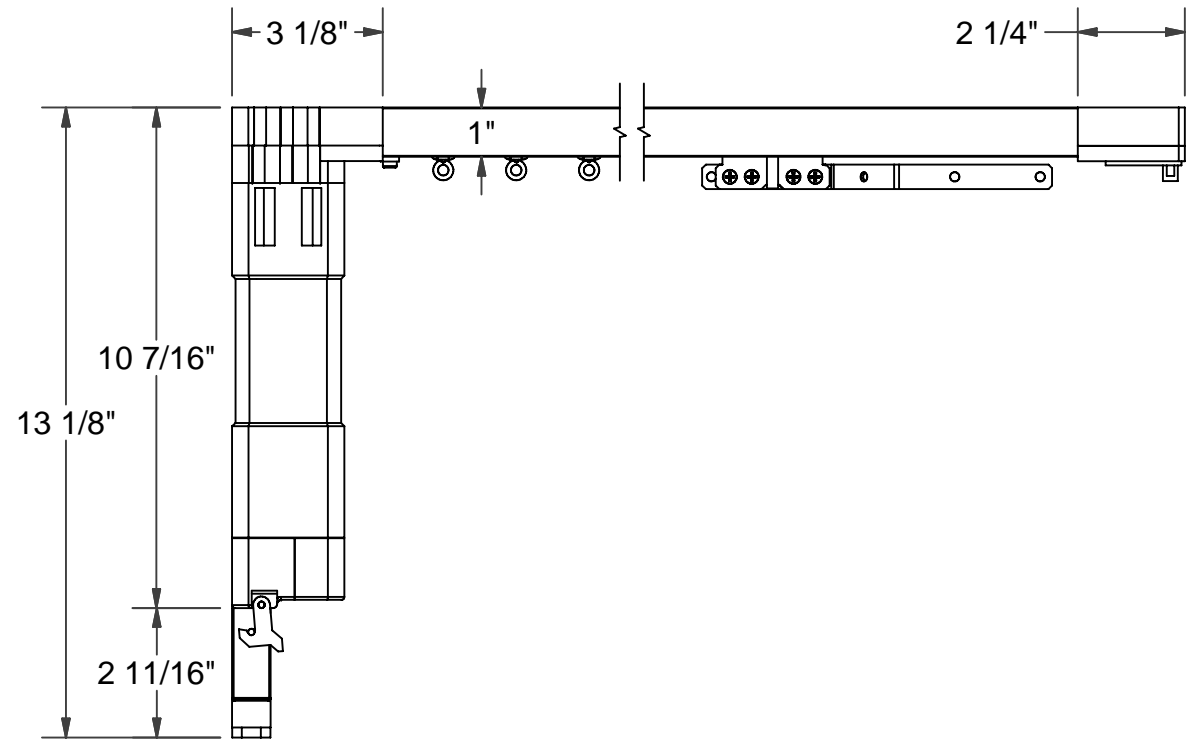
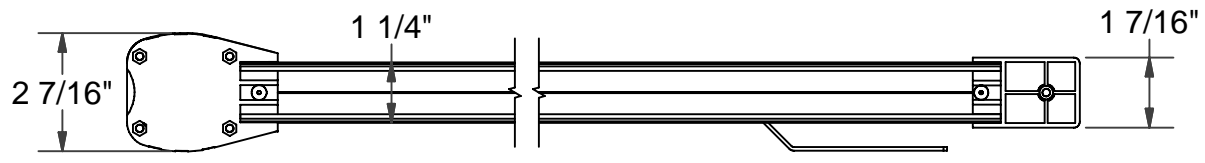

CONFIDENTIAL All information disclosed in this document is proprietary to BTX Window Automation. Holder agrees to maintain it in confidence and must not replicate or reveal this information in any manner.	Project	5060			 BTX Window Automation 10763 Sanden Dr. Dallas, Texas 75238 (214) 340-2800 (214) 343-2444 FAX
	Dim	Inches			
	TOLERANCES				
	Size	.XX ± .015	5060 45W Sofia™ Dimensions		
Size	.XXX ± .005	Matl:	Scale:	Rev	
ANG ± 1°	By: G. Bennett			Date: 16-May-08	Sheet 2 of 2

4

3

2

1

4

3



2

1

D

D

C

C

B

B

A

A

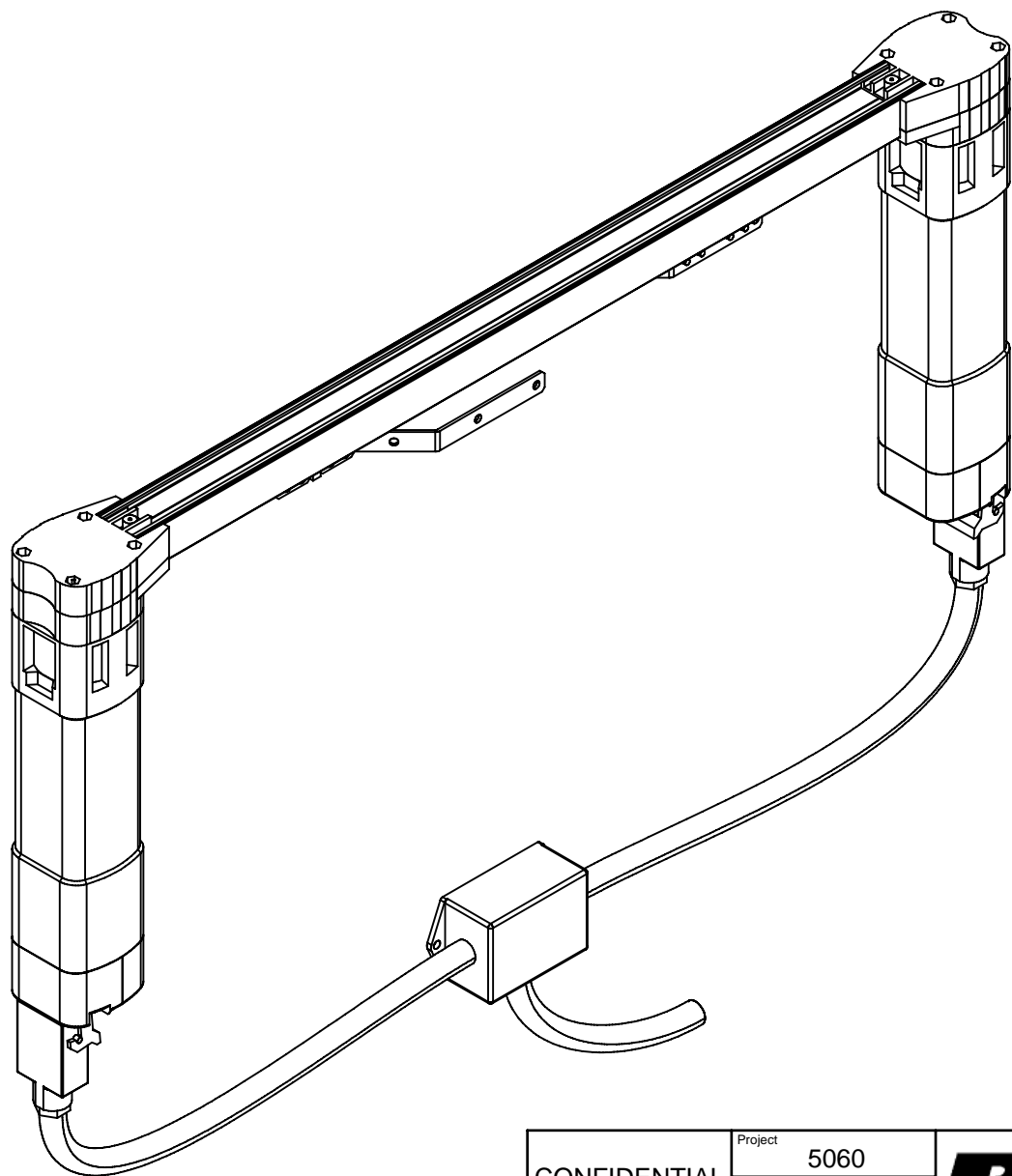

CONFIDENTIAL

All information disclosed in this document is proprietary to BTX Window Automation. Holder agrees to maintain it in confidence and must not replicate or reveal this information in any manner.

Project 5060

Dim Inches

TOLERANCES

.XX ± .015

.XXX ± .005

ANG ± 1°



BTX Window Automation
10763 Sanden Dr.
Dallas, Texas 75238
(214) 340-2800
(214) 343-2444 FAX

5060 60W Sofia™ Tandem

Size A

Matl:

Dwg No:

sofia_S_60W_tndm

Rev

By: G. Bennett

Date: 18-May-08

Scale: 1/4

Sheet 1 of 2

4

3



2

1

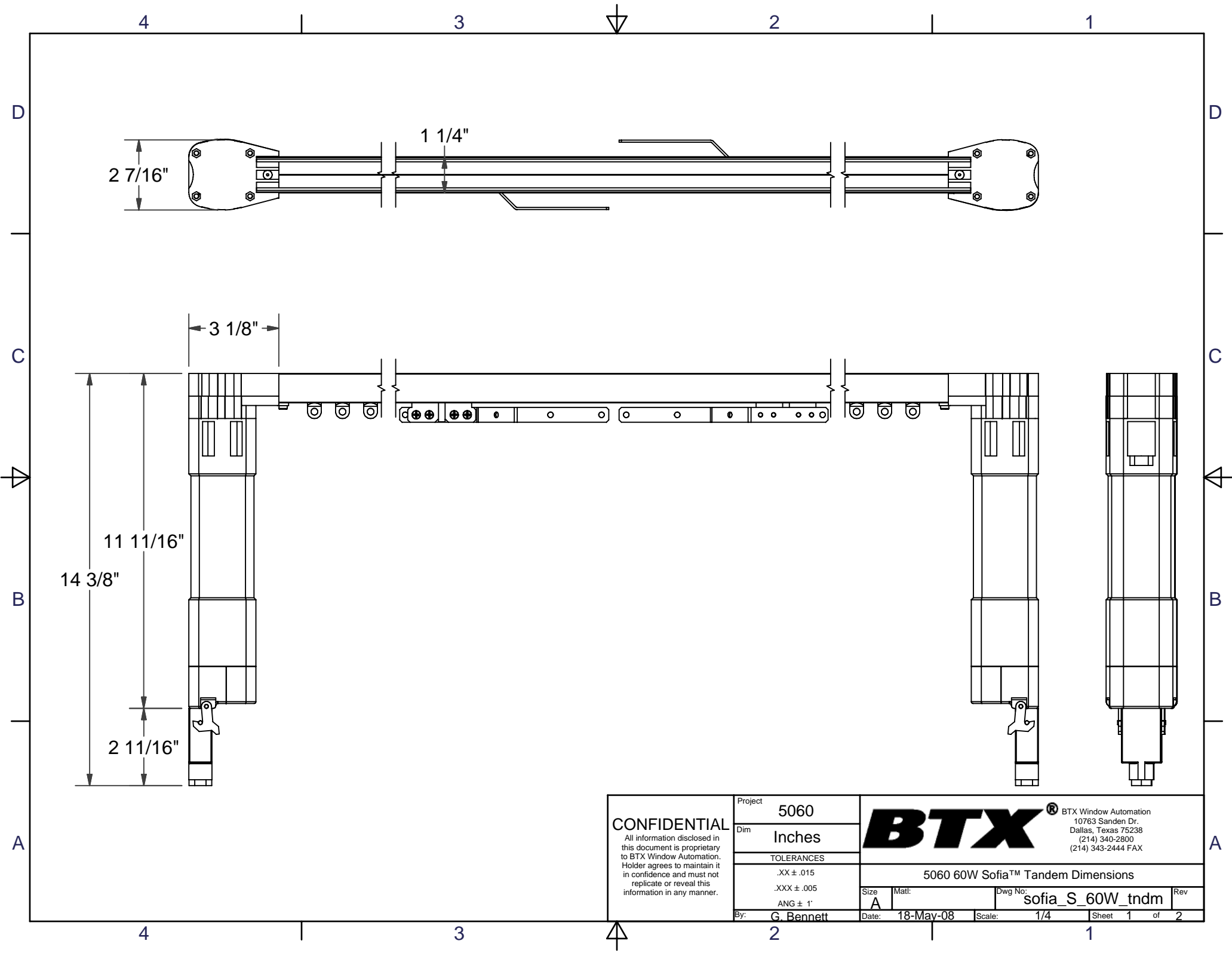

CONFIDENTIAL

All information disclosed in this document is proprietary to BTX Window Automation. Holder agrees to maintain it in confidence and must not replicate or reveal this information in any manner.

Project	5060
Dim	Inches
TOLERANCES	
.XX ± .015	
.XXX ± .005	
ANG ± 1°	
By:	G. Bennett

BTX®

BTX Window Automation
10763 Sanden Dr.
Dallas, Texas 75238
(214) 340-2800
(214) 343-2444 FAX

5060 60W Sofia™ Tandem Dimensions

Size	A	Matl:		Dwg No:	sofia_S_60W_tndm	Rev	
Date:	18-May-08	Scale:	1/4	Sheet	1	of	2

4

3



2

1

D

D

C

C

B

B

A

A

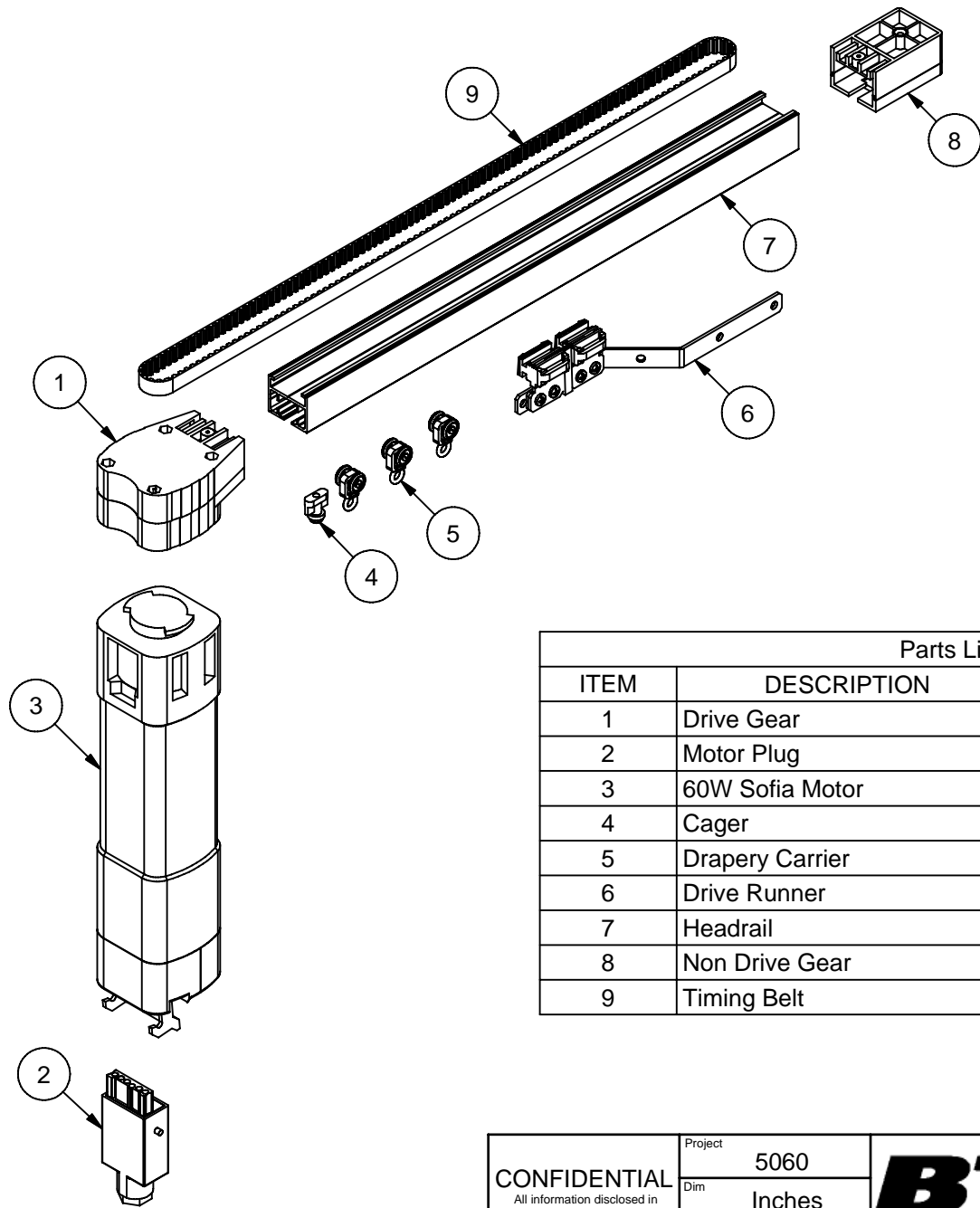

Parts List		
ITEM	DESCRIPTION	PART NUMBER
1	Drive Gear	256.7550
2	Motor Plug	440.1141
3	60W Sofia Motor	101.3349
4	Cager	240.8050
5	Drapery Carrier	240.1740
6	Drive Runner	266.4900
7	Headrail	310.5510
8	Non Drive Gear	256.1545
9	Timing Belt	290.2000

CONFIDENTIAL All information disclosed in this document is proprietary to BTX Window Automation. Holder agrees to maintain it in confidence and must not replicate or reveal this information in any manner.	Project	5060		BTX Window Automation 10763 Sanden Dr. Dallas, Texas 75238 (214) 340-2800 (214) 343-2444 FAX					
	Dim	Inches							
	TOLERANCES			5060 60W Sofia™ Parts Vew					
	Size	A							
By:	G. Bennett	Date:	16-May-08	Scale:	16-May-08	Sheet	1	of	2

D

C

B

A

4

3

2

1

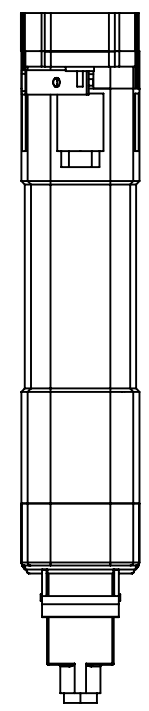
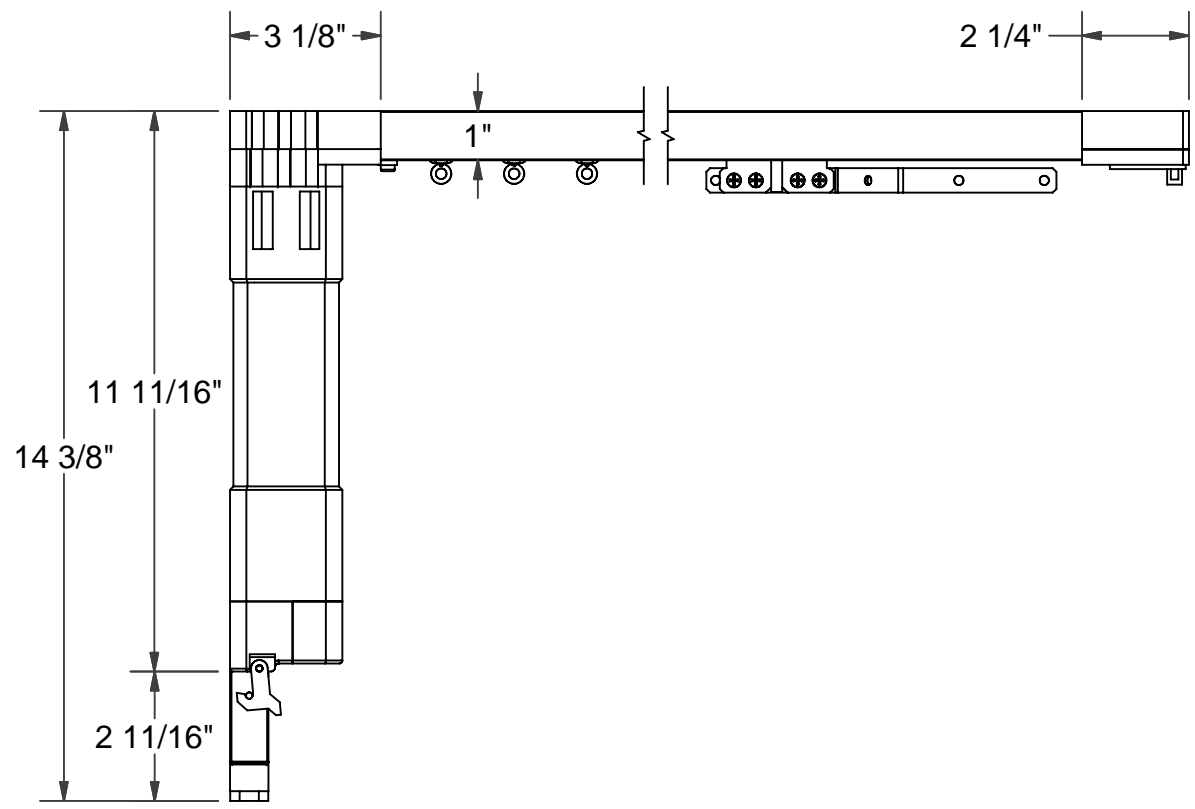
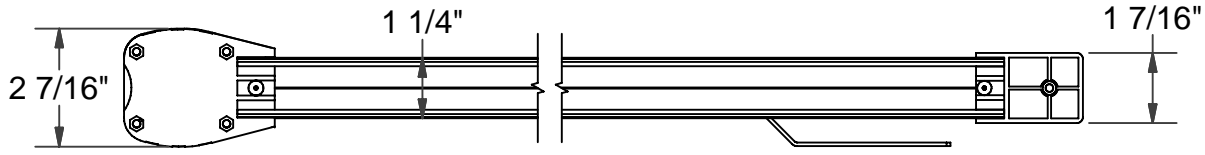

D

C

B

A

<p>CONFIDENTIAL</p> <p>All information disclosed in this document is proprietary to BTX Window Automation. Holder agrees to maintain it in confidence and must not replicate or reveal this information in any manner.</p>	Project	5060				BTX Window Automation 10763 Sanden Dr. Dallas, Texas 75238 (214) 340-2800 (214) 343-2444 FAX	
	Dim	Inches					
	TOLERANCES					5060 60W Sofia™ Dimensions	
		.XX ± .015				Size	A
	.XXX ± .005				Matl:		
	ANG ± 1°				Dwg No:	sofia_S_60W	
By:	G. Bennett			Date:	16-May-08	Scale:	16-May-08
					Sheet	2 of 2	

4

3

2

1