

**BTX**<sup>®</sup>

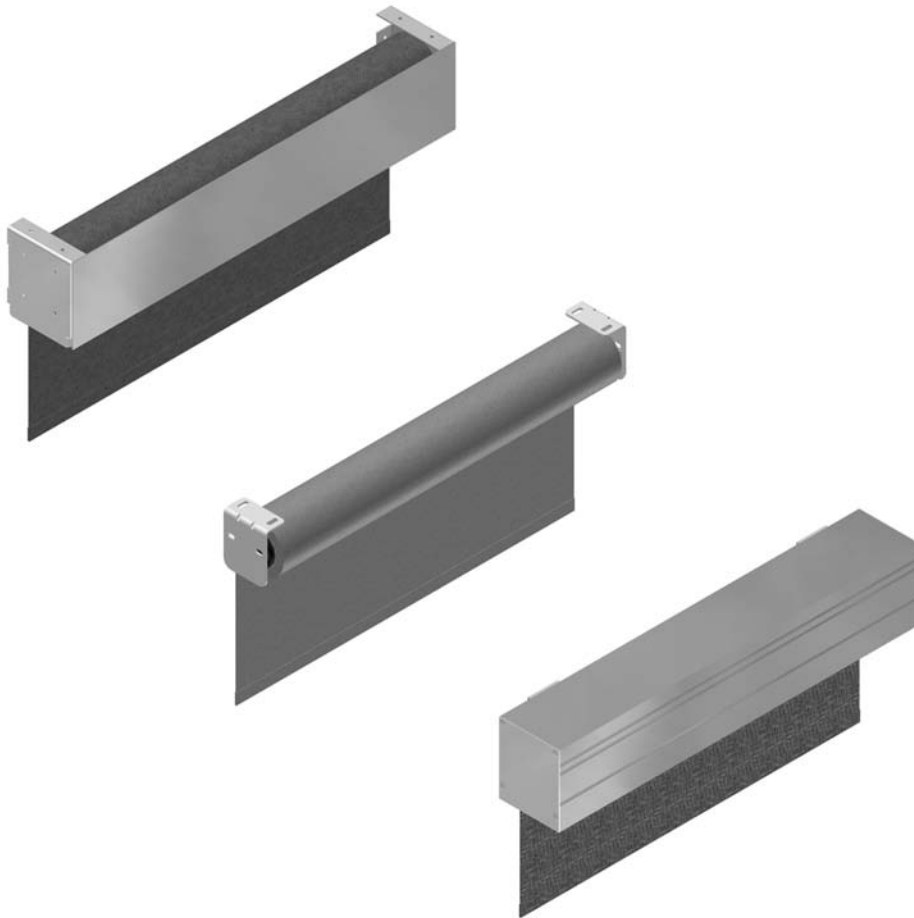

Installation Instructions for  
Motorized RS-20 Easy-Set<sup>™\*</sup>

**RS-20 Easy-Set<sup>™\*</sup>**

**BTX Easy-Set™  
roller shade  
systems consist  
of modular  
components for  
easy installation**

**Tools Required:**

Power Screwdriver

Level

Square

Pliers

Test Cable

Rubber Mallet  
(for fascia)

Masking Tape

Small Phillips

Small Flathead

Drill Bits

Screws & Anchors

**Optional Tools:**

Caulking  
& Shims

# Table of Contents

## Installing the Easy-Set™ Bracket System

Bracket System Instructions . . . . .	2
Bracket System with Coupler Instructions . . . . .	3
Bracket System Removal . . . . .	5

## Installing the Easy-Set™ Fascia System

Fascia System Instructions . . . . .	7
Fascia System with Coupler Instructions . . . . .	9

## Installing the Easy-Set™ Cassette System

Cassette System Instructions . . . . .	11
Cassette System with Coupler Instructions . . . . .	14
Limit Adjustment Instructions (DC Motor) . . . . .	16
Limit Adjustment Instructions (AC Motor) . . . . .	17
RS Shade Maintenance . . . . .	18

Warranty & Return Policy . . . . .	19
------------------------------------	----



# Installing the Easy-Set™\* Bracket System

Ref. #	Description	Bracket System
1	Motor End Bracket	
2	Spring Idler	
3	Idler End Bracket	
4	Motor	
5	Crown Adapter	
6	55 mm Aluminum Tube	
7	Drive Adapter	
8	Nylon Shaft Bearing	
9	Cotter Pin	

**Note:** Prior to installation check to make sure that mounting surfaces are solid and strong enough to support the systems.

- Roller shades must be mounted at an exact horizontal level to prevent fabric from telescoping (traveling sideways to its lowest point). If mounting surfaces are not level, support brackets must be shimmed for corrections (see fig. 1). Minor corrections may be made on installed tubes by shimming the lower tube end with adhesive tape.
- Install the motor and idler brackets with screws to a solid surface (see fig. 3).
- Insert idler end of shade assembly into idler end bracket (see fig. 4).
- Bring motor end up and insert the rectangular shaft into the motor end bracket and secure with cotter pin (see fig. 5).
- Your assembly should now look like image at right. (see fig. 6).
- Completely tighten bracket screws and make sure shade is secure. Check to see if shade is level.
- Check shade operation individually for each motor system using a test cable. At this point, do not connect to wired or control system. If necessary adjust limits (see limit setting instructions).
- Once limits are adjusted to desired setting, run shade to check that fabric is level and no further adjustments are needed. Shim if necessary (see step 1).
- Connect the motor wire to the existing pre-wire or controls. Test motor system on home/building wiring and controls.

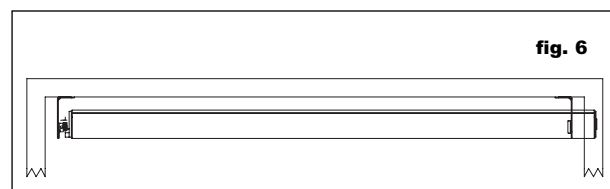
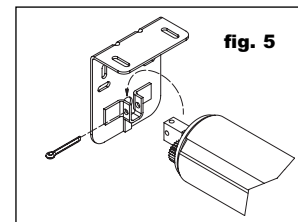
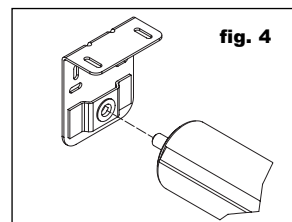
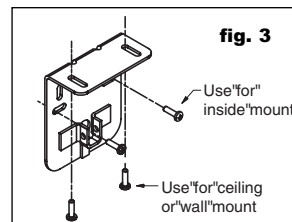
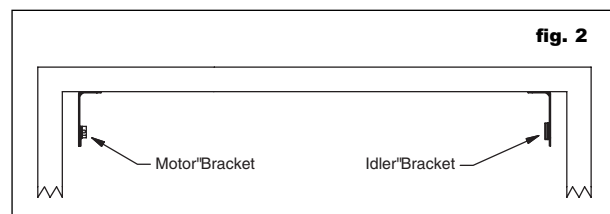
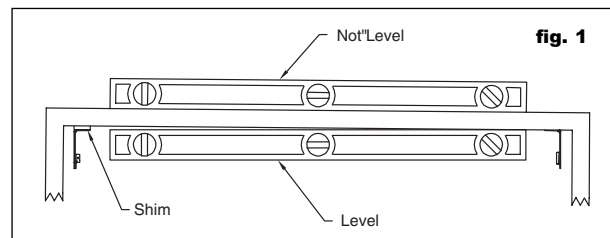

**NOTE:** Electrical wire connection must be done by a licensed electrician in accordance with the prevailing codes.

# Installing the Bracket System with Coupler

Ref. #	Description	Bracket Coupler Sub-Assembly
1	Cotter Pin	
2	Nylon Shaft Bearing	
3	Spring Coupler	
4	Female Idler	
5	Crown Adapter	
6	55 mm. Aluminum Tube	
7	Center Support Bracket	

**Note:** Prior to installation check and make sure that mounting surfaces are solid and strong enough to support the system.

1. Roller shades must be mounted at exact horizontal level to prevent fabric from telescoping (travel sideways to its lowest point). If mounting surfaces are not level, support brackets must be shimmed for corrections (see fig. 1). Minor corrections may be made on installed tubes by shimming the lower tube end with adhesive tape.
2. Install the Motor Bracket, Idler Bracket, and Center Support Bracket with screws to a solid surface, checking to see that they are square and plumb to each other (see fig. 2). The coupled shade consist of at least two tube/fabric assemblies: Main system contains the motor—secondary system with female idler coupler.
3. Take assembled motor tube (main system) and insert the spring—loaded hex shaft into the coupler bushing on the center support bracket (see figures 3 and 4).
4. Bring motor end up and insert the rectangular shaft into the motor end bracket and secure both the motor bracket and center support bracket with the cotter pin. (see fig. 5).

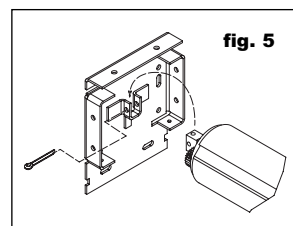
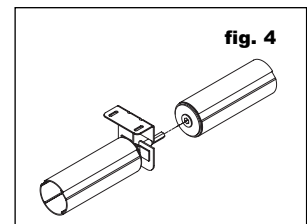
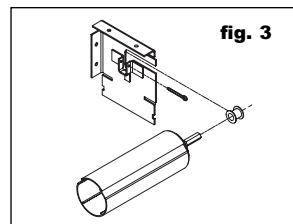
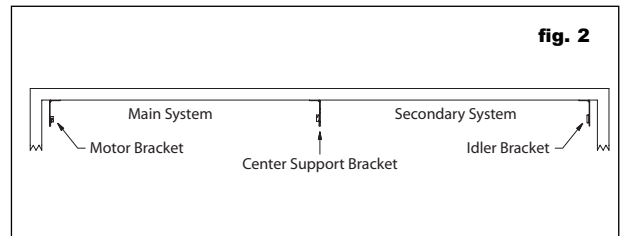
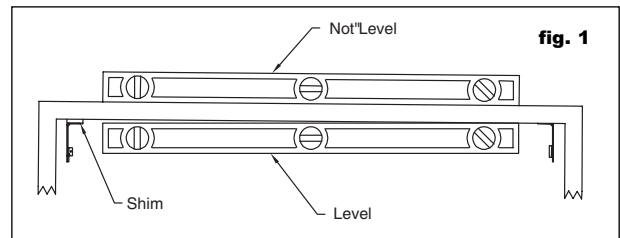

## Installing the Bracket System with Coupler (cont.)

- Your assembly should now look like image at the right (see **fig. 6**).
- Insert idler end of secondary shade assembly into idler end bracket (see **fig. 7**).
- While holding secondary assembly in place, use a screwdriver or other tool to depress the hex shaft on the spring coupler (see **fig. 8**).
- There will be orientation marks on both the hex shaft and female idler on the secondary system. Line marks up so that the fabric will be lined up in its' operation. While keeping the hex shaft fully depressed, bring the end of the secondary assembly up and hold in place. Remove screw-driver and allow hex shaft to pop into the female idler (see **fig. 9**).
- Your assembly should now look like the image at the right (see **fig. 10**).
- Check that all screws are tight and make sure your shade is secure. Check to see if shade is level.
- Check shade operation individually for each motor system using a test cable. Do not test with network or control system. If necessary, adjust limits (see **limit instructions**).
- Once limits are adjusted to desired setting, run shade to check that fabric is level and no further adjustments are needed. Shim if necessary (see **step 1**).
- Connect the motor wire to the existing pre-wire or controls. Test motor system on home/building wiring and controls.

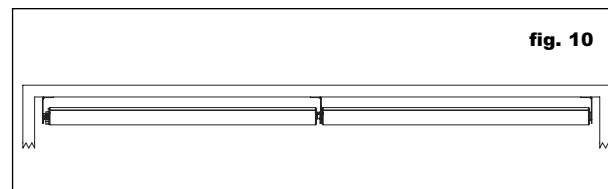
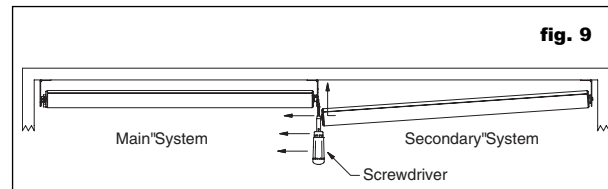
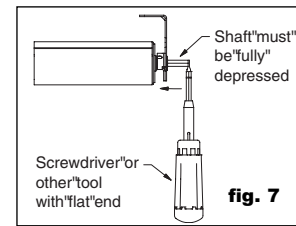
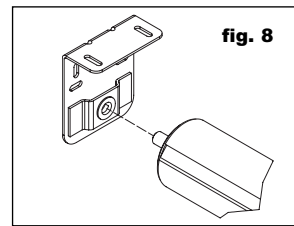
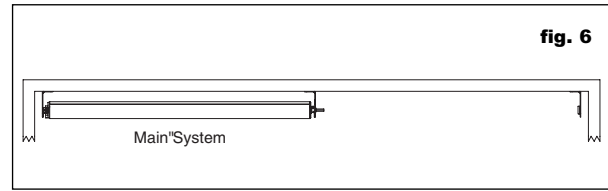

**NOTE: Electrical wire connection must be done by a licensed electrician in accordance with prevailing codes.**

# Removing the Bracket System with Coupler

**Note:** It is not necessary to loosen or remove the brackets

1. Work from the motor end to the idler end of the system. The illustration shows the motor mounted on the left side of the system. Depending on specifications the motor may be left mounted or right mounted (see fig. 1).
2. Begin by removing the cotter pin from the motor end of the assembly (see fig. 2).
3. **Support the secondary system near the center support!**
4. Take cotter pin out of system bracket.
5. Drop the end of the main system down while supporting the secondary system. Once the main system is removed, the secondary system will no longer be attached and could drop (see fig. 3).
6. Lift the main system out and away from the center support until the hex shaft on the spring coupler is free from the female idler. Continue to support the secondary system so that it does not fall (see fig. 4).
7. The secondary system can now be removed by dropping the end that is closest to the center support and pulling away until the spring idler is clear of the idler end bracket. The removal of the system is now complete (see fig. 5).

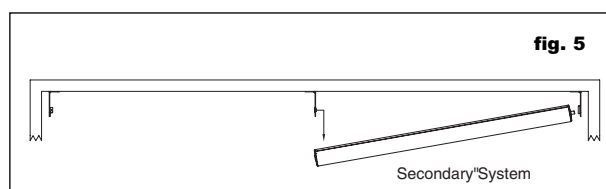
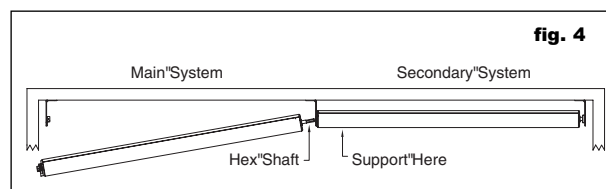
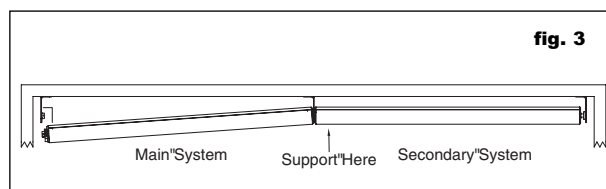
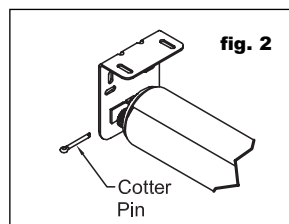
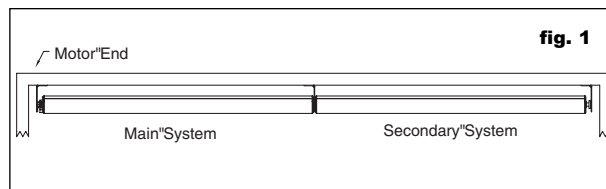

# Installing the Easy-Set™\* Fascia System

Ref. #	Description	Fascia System
1	Fascia Motor End Bracket	
2	Spring Idler	
3	Fascia Idler End Bracket	
4	Fascia	
5	Motor	
6	Crown Adapter	
7	55 mm. Aluminum Tube	
8	Drive Adapter	
9	Bushing	
10	Closure	
11	Setscrew (optional)	
12	Mounting Screw (optional)	
13	End Cap	
14	Cotter Pin	

**Note:** Prior to installation check and make sure that mounting surfaces are solid and strong enough to support the system.

1. Roller Shade and brackets must be mounted at exact horizontal level to prevent fabric from telescoping (travel sideways to its lowest point). If mounting surfaces are not level, brackets must be adjusted to compensate (see fig. 1).
2. Attach the drop-in mounting brackets with screws to a solid surface.  
 Inside mount: (see fig. 2A)  
 Wall mount: (see fig. 2B)  
 Inside mount: (see fig. 2C)
3. Insert the idler shaft into the bushing on the idler end of the assembly (see fig. 3 and 4).

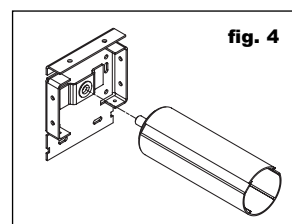
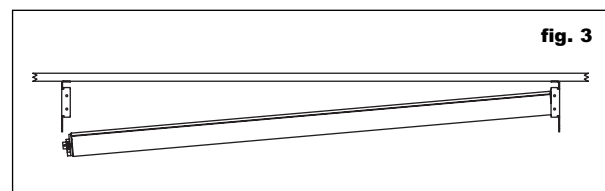
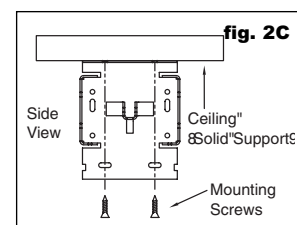
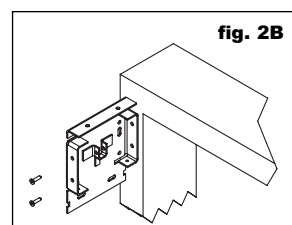
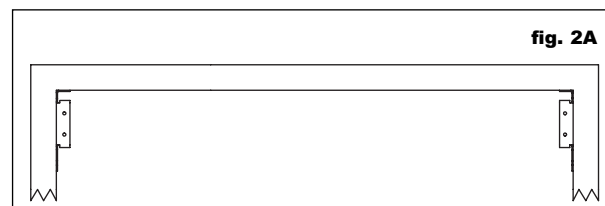
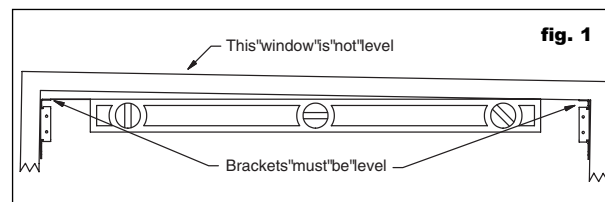

## Installing the Easy-Set™\* Fascia System (cont.)

4. Bring motor end up and insert the rectangular shaft into the motor end bracket and secure the motor end in the bracket with the cotter pin (see fig. 5).
5. Your assembly should now look like the image to the right (see fig. 6).
6. Completely tighten screws and make sure your shade is secure. Check to see if shade is level.
7. With a test cable run shade to check that fabric is level and no further adjustments are needed. Shim if necessary.
8. Connect the motor wire to the existing pre-wire or controls.
9. Snap on Fascia (see fig. 7).
10. Install optional closure, if provided (see fig. 8).

**NOTE: Electrical wire connection must be done by a licensed electrician in accordance with prevailing codes.**

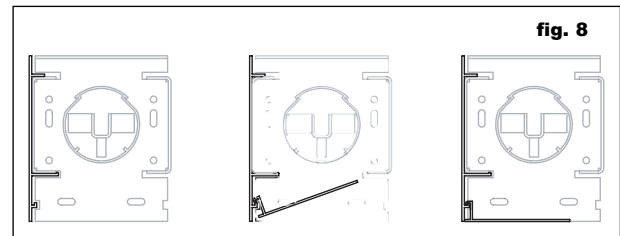
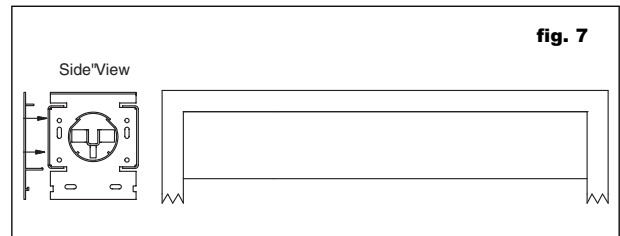
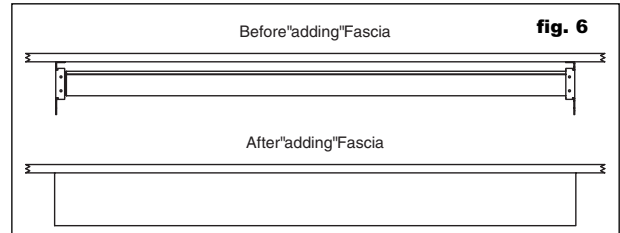
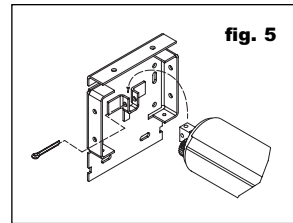

# Installing the Fascia System with Coupler

Ref. #	Description	Fascia Coupler Sub-Assembly
1	Nylon Shaft Bearing	
2	Cotter Pin	
3	Spring Coupler	
4	Female Idler	
5	Crown Adapter	
6	55 mm. Aluminum Tube	
7	Fascia Coupler Bracket	

**Note:** Prior to installation check and make sure that mounting surfaces are solid and strong enough to support the system.

- Roller shades must be mounted at an exact horizontal level to prevent fabric from telescoping (travel sideways to its lowest point). If mounting surfaces are not level, support brackets must be shimmed for corrections (see fig. 1). Minor corrections may be made on installed tubes by shimming the lower tube end with adhesive tape.
- Install the Motor Bracket, Idler Bracket, and Center Support Bracket with screws to a solid surface, checking to verify that they are square and plumb to each other (see fig. 2). The coupled shade consists of at least two tube/fabric assemblies: Main system contains the motor—secondary system with female idler coupler.
- Take assembled motor tube (main system) and insert the spring—loaded hex shaft into the coupler bushing on the center support bracket (see fig. 3 and fig. 4).
- Bring motor end up and insert the rectangular shaft into the motor end bracket and secure both the motor bracket and center support bracket with the cotter pin (see fig. 5).

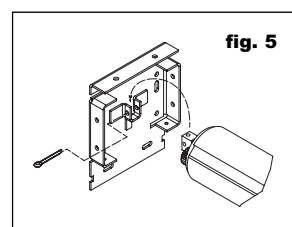
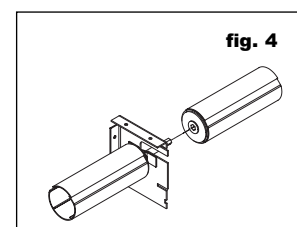
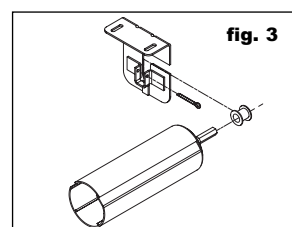
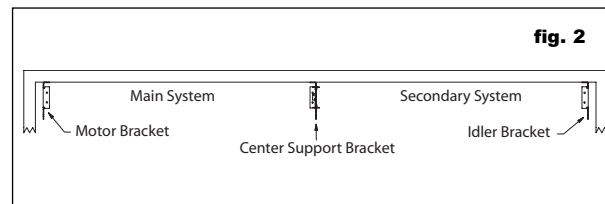
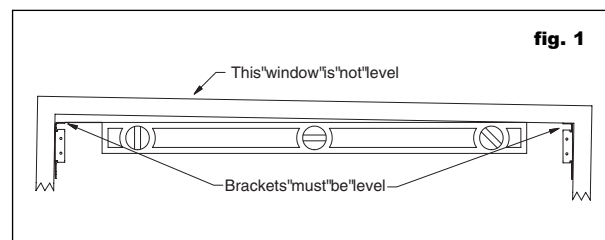

## Installing the Fascia System with Coupler (cont.)

5. Your assembly should now look like the image to the right (see fig. 6).
6. Insert idler end of secondary shade assembly into idler end bracket (see fig. 7).
7. While holding secondary assembly in place, use a screwdriver or other tool to depress the hex shaft on the spring coupler (see fig. 8).
8. There will be orientation marks on both the hex shaft and female idler on the secondary system; Line these marks up so that the fabric will be lined up in its operation. While keeping the hex shaft fully depressed, bring the end of the secondary assembly up and hold in place. Remove the screwdriver and allow hex shaft to pop into the female idler (see fig. 9).
9. Your assembly should now look like the image to the right (see fig. 10).
10. Check that all screws are tight and make sure your shade is secure. Check to see if shade is level.
11. Check shade operation individually for each motor system using a test cable. Do not test with network or control system. If necessary, adjust limits (see limit instructions).
12. Once limit is adjusted run shade to check that fabric is level and no further adjustments are needed. Shim if necessary (see step 1).
13. Connect the motor wire to the existing pre-wire or controls. Test motor system on home and building wiring and control.
14. Snap on Fascia (see fig. 11).
15. Install optional closure, if provided (see fig. 12).

**NOTE: Electrical wire connection must be done by a licensed electrician in accordance with prevailing codes.**

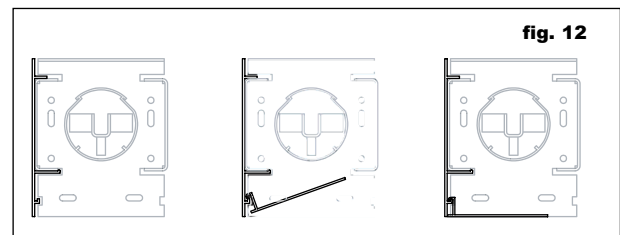
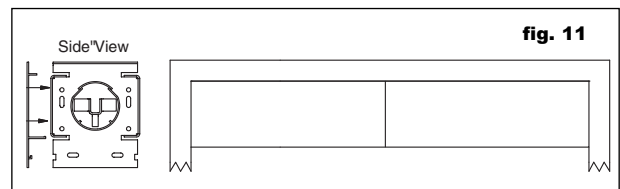
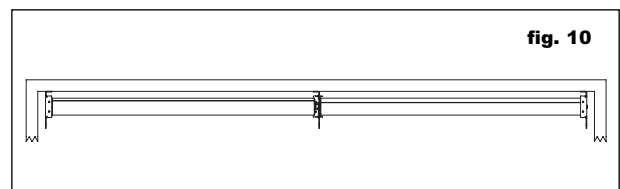
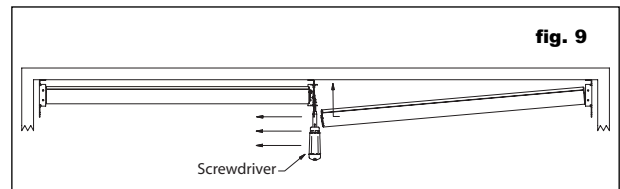
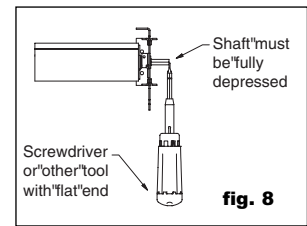
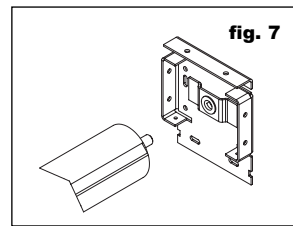
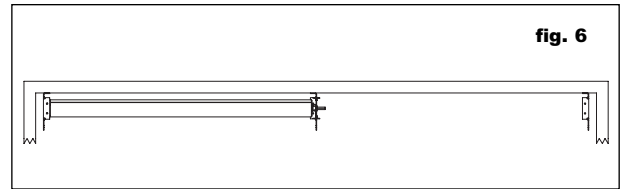

# Installing the Easy-Set™\* Cassette System

Ref. #	Description	Cassette System
1	Motor End Plate	
2	Idler End Plate	
3	4" Cassette	
4	Motor	
5	Crown Adapter	
6	Drive Adapter	
7	Idler Bushing	
8	Spring Idler	
9	55mm Aluminum Tube	
10	Closure	
11	Hanger Bracket	
12	Inside Mounting Bracket.	
13	Cotter Pin	

**Note:** When using inside mounting bracket, motorized tube has been installed into cassette before hanging onto bracket.

1. Roller Shade and Cassette must be mounted at exact horizontal level to prevent fabric from telescoping (traveling sideways to its lowest point). If mounting surfaces are not level, brackets must be adjusted to compensate (see fig. 1).
2. **For the wall mount:** Attach the drop-in mounting brackets with screws to a solid surface. The brackets must be level, square and plumb to one another (see fig. 2A).

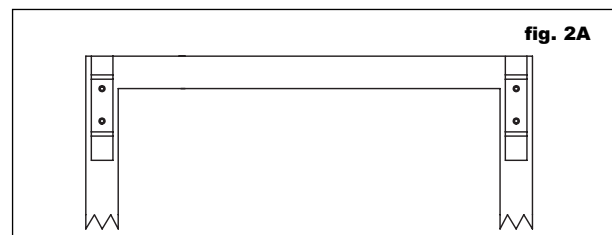
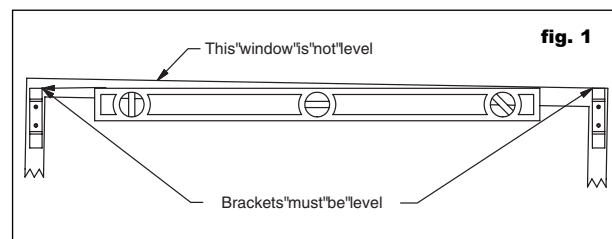

**For the inside mount:** Install the inside mounting brackets with screws to a solid support (see fig. 2B).

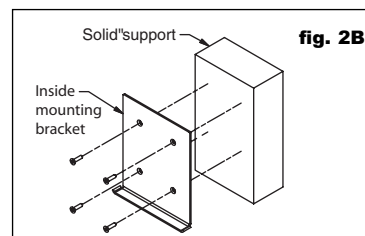

**For the ceiling mount:** Drill holes in cassette box and secure to solid supports with screws (see fig. 2C). If you are using a center support—couple two or more tubes together, alternate screw locations on either side of the center support channel.

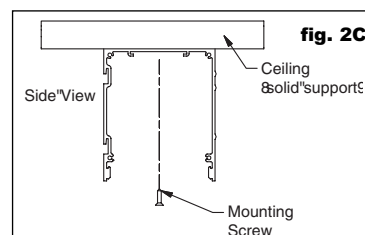

# Installing the Easy-Set™\* Cassette System

3. **For wall mount:** Position the cassette box so that the grooves in the back line up with the extensions on the mounting brackets. Drop the cassette box down until the box seats into place on the mounting brackets (**see fig. 3A**).

To secure the cassette box to the mounting brackets, insert self-tapping screw (**see fig. 3B**).

**Inside mount:** box will rest on the extensions of the inside mounting brackets (**see fig. 3C**).

**Ceiling mount:** for secure attachment, mounting screws must be set at intervals of 20" minimum. (**see fig. 3D**)

4. The cassette is designed to be as small as possible. You may have to unroll some fabric for the tube to be able to drop the motor shaft into the bracket. Unroll the fabric from the tube and insert the idler shaft into the bushing on the idler end of the assembly (**see fig. 4 and 5**).
5. Bring motor end up and insert the rectangular shaft into the motor—bracket and secure with the cotter pin (**see fig. 6**).

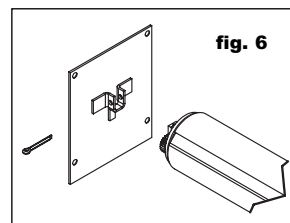
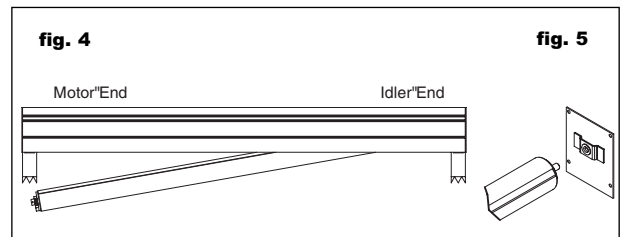
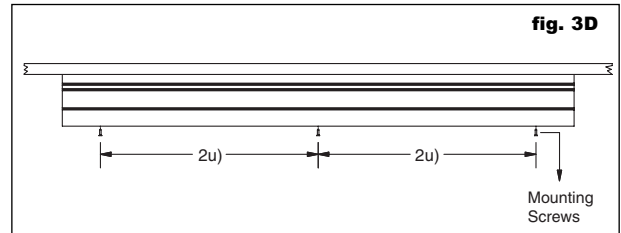
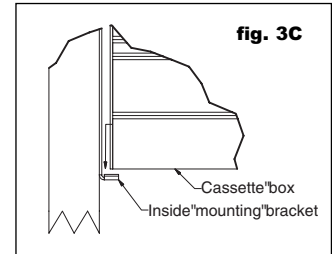
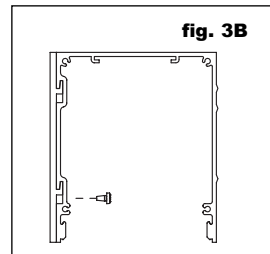
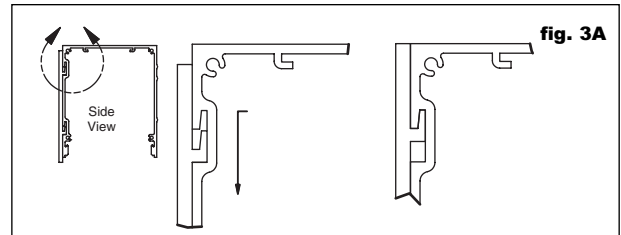

# Installing the Easy-Set™\* Cassette System

6. Your assembly should now look like the image to the right.

Wall Mount: (see fig. 7A)

Inside Mount: (see fig. 7B)

Ceiling Mount: (see fig. 7C)

7. Completely tighten screws and make sure your shade is secure. Check to see if shade is level.
8. Adjust limits with test cable, if necessary.
9. Run shade to check that fabric is level and no further adjustments are needed. Shim if necessary.
10. Connect the motor wire to the existing pre-wire or controls.
11. The optional closure may be attached at this time. (see fig. 8)

**NOTE: Electrical wire connection must be done by a licensed electrician in accordance with prevailing codes.**

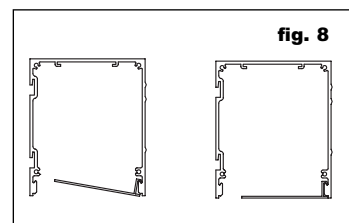
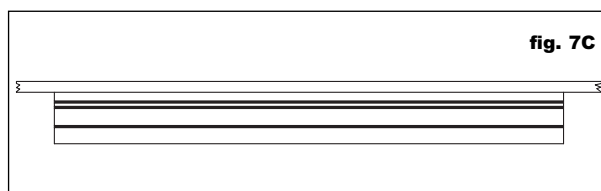
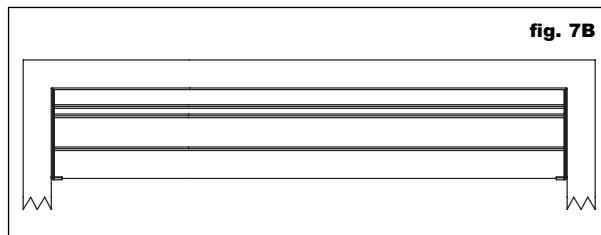
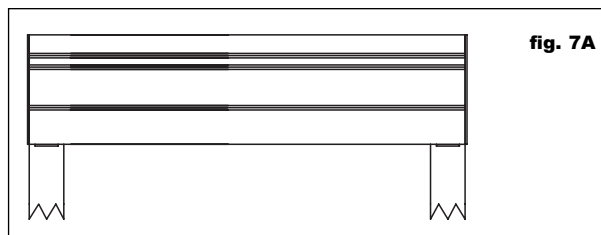

# Installing the Cassette System with Coupler

Ref. #	Description	Cassette Coupler Sub-Assembly
1	Nylon Shaft Bearing	
2	Cotter Pin	
3	Spring Coupler	
4	Female Idler	
5	Crown Adapter	
6	55 mm. Aluminum Tube	
7	Fascia Coupler Bracket	
8	4" Cassette	
9	Optional Set Screws	

**Note:** Prior to installation check and make sure that mounting surfaces are solid and strong enough to support the system.

1. Install the cassette (either wall, ceiling or inside mount) as per instructions in previous section (see fig. 1).
2. The support bracket should be in the center support channel. Slide to desired position (see fig. 2).
3. Take assembled motor tube (main system) and insert the spring-loaded hex shaft into the coupler bushing on the center support bracket (see figures 3 and 4).
4. Bring motor end up and insert the rectangular shaft into the motor end bracket and secure both the motor bracket and center support bracket with the cotter pin (see fig. 5).

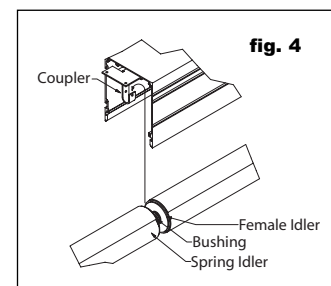
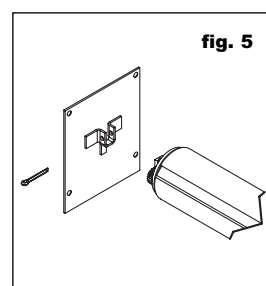
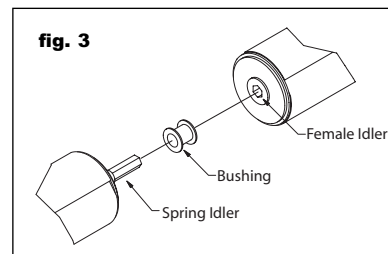
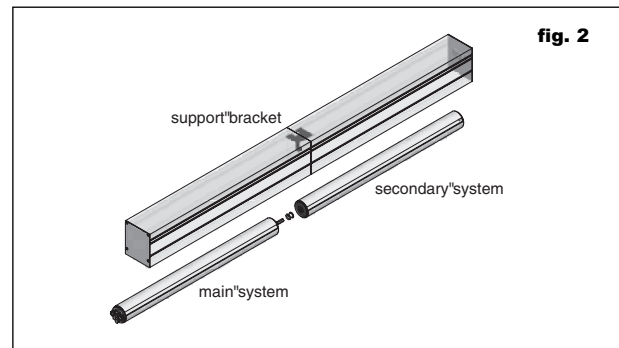
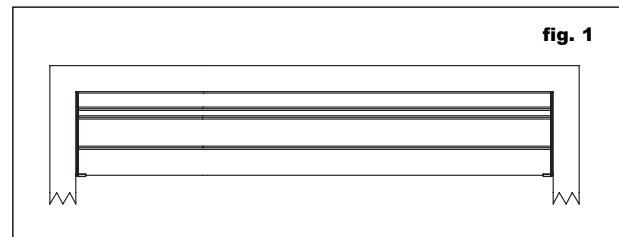

## Installing the Cassette System with Coupler (cont.)

5. Your assembly should now look like the image to the right (**see fig. 6**).
6. Insert idler end of secondary shade assembly into idler end bracket (**see fig. 7**).
7. While holding secondary assembly in place, use a screwdriver or other tool to depress the hex shaft on the spring coupler (**see fig. 8**).
8. There will be orientation marks on both the hex shaft and female idler on the secondary system. Line marks up so that the fabric will be lined up in its' operation. While keeping the hex shaft fully depressed, bring the end of the secondary assembly up and hold in place. Remove screwdriver and allow hex shaft to pop into the female idler (**see fig. 9**).
9. Your assembly should now look like the image to the right (**see fig. 10**).
10. Check that all screws are tight and make sure your shade is secure. Check to see if shade is level.
11. Check shade operation individually for each motor system using a test cable. Do not test with network or control system. If necessary, adjust limits (**see limit instructions**).
12. Once limits are adjusted to desired setting, run shade to check that fabric is level and no further adjustments are needed. Shim if necessary (**see step 1**).
13. Connect the motor wire to the existing pre-wire or controls. Test motor system on home/building wiring and controls.

**NOTE: Electrical wire connection must be done by a licensed electrician in accordance with prevailing codes.**

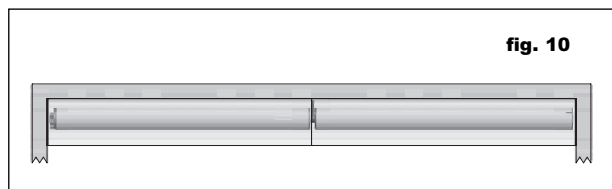
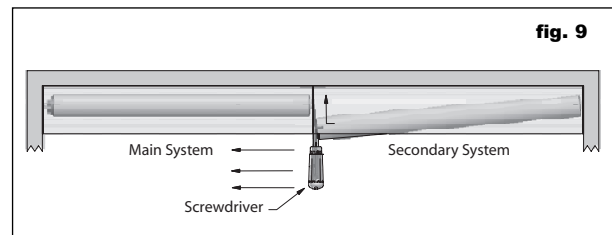
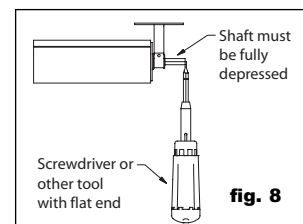
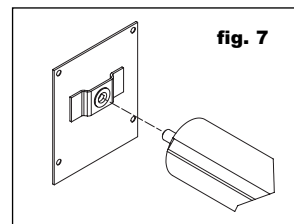
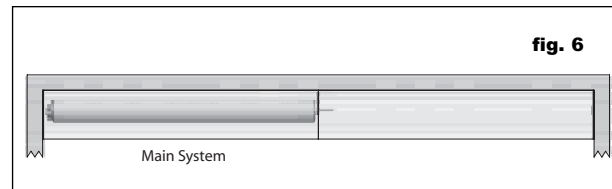

# Limit Adjustment Instructions - DC Motor

The maximum limit switch range for this motor is 29 revolutions. A 4mm Allen key is required for adjustments.

<p>Identify the limit switch adjusting screws from the direction of travel arrows.</p> <p>Turn the limit switch adjusting screws to:</p> <p><b>minus (-) = shorter travel</b>  <b>plus (+) = longer travel</b></p>	

1. Allow the motor to run completely in the down or closed position. If the motor stops before you want it to, continue to engage the control or test cable in the down position and turn the down or closed limit switch, adjusting the screw in the “plus” direction until the desired end position is reached. If the motor overruns the down or closed position, turn the down or closed limit switch, adjusting the screw in the “minus” direction one full turn. Run the shade up or into the open position about a foot, then run it down and see if the one turn of the screw was enough. If not, repeat the process.
2. If the up or open limit needs adjustment, follow the instructions in the paragraph above for setting, using the up or open limit switch adjusting screws.
3. Run the motor alternately in both directions until the limit switches trip. Fine-tune the limit switch settings if necessary. One turn of the adjusting screw approximately corresponds to a 90 degree turn of the tube.



## Tip . . .

The limit switches function only when the motor is installed in the tube. If you are going to check limits without the motor in the tube, you must rotate the crown in the same direction the drive shaft is turning while the motor is running.

**NOTE: The motor has a running time of approximately six minutes before the built-in thermal overload shuts the motor off. If the motor stops operating, allow it to cool down for at least 15 minutes before trying to switch it on again.**

# Limit Adjustment Instructions - AC Motor

The maximum limit switch range for this motor is 21 revolutions. If installing a 32-revolution motor, proceed as described under "Extended Limit Switch Range Setting". A gear-adjusting tool is required for adjustment.

1. Allow the motor to run completely in the down or closed position. If the motor stops before you want it to, continue to engage to control or test cable in the down position and turn the down or closed limit switch, adjusting the screw in the "(+ plus)" direction until the desired end position is reached. If the motor overruns the down or closed position, turn the down or closed limit switch, adjusting the screw in the "(- minus)" direction one full turn. Run the shade up or into the open position about a foot, then run it down and see if the one turn of the screw was enough. If not, repeat the process.
2. If the up or open limit needs adjustment, follow the instructions in the paragraph above for setting, using the up or open limit switch adjusting screws.
3. Run the motor alternately in both directions until the limit switches trip. Fine-tune the limit switch settings if necessary. One turn of the adjusting screw approximately corresponds to a 90 degree turn of the tube.

**NOTE: The motor has a running time of approximately six minutes before the built-in thermal overload shuts the motor off. If the motor stops operating, allow it to cool down for at least 15 minutes before trying to switch it on again.**

## Extended Limit Switch Range Setting

If more than 21 revolutions of the tube are necessary, the motor must be switched on in the "down" direction until the motor cuts out. Do not attach the shade fabric until then. Hold the "down" switch depressed and turn limit switch, adjusting the screw "down" in the "minus" direction until the motor has made approximately eight revolutions of the tube.

Identify the limit switch adjusting screws from the direction of travel arrows. Turn the limit switch adjusting screws to:

**minus (-) = shorter travel**

**plus (+) = longer travel**

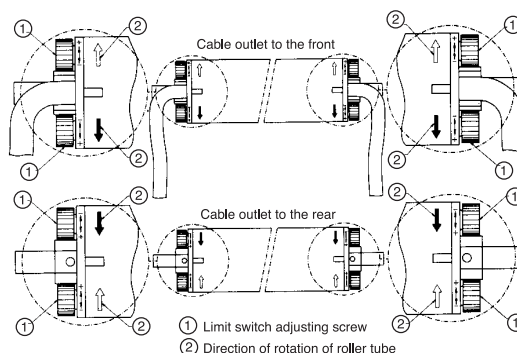

## Tip . . .

The limit switches function only when the motor is installed in the tube. If you are going to check limits without the motor in the tube, you must rotate the crown in the same direction the drive shaft is turning while the motor is running.

# RS Shade Maintenance

---

## Hardware

The BTX RS Series manual and motorized shades are designed to be virtually maintenance free.

## Fabric

Fabric care is dependent on the composition of the material selected. Fabric panels should roll up evenly on the roller tube. If any irregularity occurs over time it should be corrected to prevent damage to fabric edges. Shim to correct problems in rolling fabric up.

PVC-coated materials (780 material, E-screen, T-screen and Phifer) should be cleaned with a brush. Use mild detergent and rinse.

Acrylics (Flocke): Remove dust with a vacuum cleaner, clean with sponge, cold water and mild detergent (5%). Dry in an upright position with blind open.

**NOTE: Do not rub fabric hard, as this may discolor it.**

# Warranty & Return Policy

## 1. Contract

All offers, "quotes" and "sales" by BTX Window Automation, Inc. ("BTX") are subject to these Terms and Conditions of Sale. No other agreements have been made or will be valid unless expressly confirmed in writing by BTX.

## 2. ACCEPTANCE

BY TAKING DELIVERY OF BTX PRODUCTS, PURCHASER ASSENTS TO THE TERMS AND CONDITIONS STATED HEREIN, UNLESS OTHERWISE EXPRESSLY AGREED IN WRITING BY BTX. BTX HEREBY OBJECTS TO ANY DIFFERENT OR ADDITIONAL TERMS AND CONDITIONS WHICH MAY BE PROPOSED OR HAVE BEEN PROPOSED BY PURCHASER IN ANY PURCHASE ORDER FORMS OR OTHER DOCUMENTS. THE TERMS AND CONDITIONS STATED HEREIN SHALL PREVAIL OVER ANY DIFFERENT OR ADDITIONAL TERMS AND CONDITIONS PROPOSED BY PURCHASER AND SHALL APPLY TO THE SALE OR SHIPMENT OF ANY GOODS IN RESPONSE TO PURCHASER'S ORDER.

## 3. Prices and Delivery

All quoted prices are valid for a period of 60 days from the date of issue, unless otherwise agreed by BTX in writing. Prices on accepted orders remain firm for a period of four months from the date of order acceptance, provided final delivery occurs within that period. If delivery is to occur more than four months from the date of order acceptance, prices are subject to change in accordance with any changes in the published BTX price list which occur after the date of order acceptance. All prices quoted are FOB Dallas, excluding all freight, packaging and taxes. All delivery dates are approximate.

## 4. Payment Terms

(a) Open account payment terms may be established from time to time at the sole discretion of BTX, and are subject to credit approval in writing. Terms on open accounts are payment in full, net x days from date of invoice. Payment terms for single transactions and transactions other than on open account are net C.O.D. or prepay unless confirmed otherwise in writing by BTX.

(b) Amounts past due are subject to a finance charge of w.y.% per month to the legal limit, and the finance charge will apply without further prior notice. In case of purchaser's delinquency in payment or insolvency, BTX retains the right to halt or interrupt all further deliveries and service to the purchaser until all past due amounts have been paid, and to require payment in advance for orders not yet delivered, without any liability resulting for BTX. Purchaser expressly agrees to indemnify BTX and hold BTX harmless from all charges and liability which might arise in any manner from purchaser's nonpayment.

## 5. Inspection, Acceptance and Claims

All claims by purchaser against BTX for shortages must be made in writing to BTX within fourteen days from date of shipment from BTX's Dallas base or they are waived. Any claims for transport damage are the responsibility of the recipient and must therefore be filed with the carrier by the recipient.

## 6. Risk of Loss

Full risk of loss, damage or destruction of the goods shall pass to purchaser upon delivery of the goods to the carrier at the point of shipment or upon delivery at storage, whichever applies.

## 7. Force Majeure

If an order cannot be completed due to causes beyond BTX's control, BTX retains the right to either cancel the uncompleted portion of the order or complete the order if and when this becomes possible. Purchaser shall not have the right to withhold payment on delivered goods and/or services, nor to unilaterally change the order or cancel same. Force majeure includes but is not limited to strikes, lock-outs, storms, floods and the like, terrorism, wars, revolutions, major equipment failures or fire damage at production facilities, etc.

## 8. Warranty

BTX extends a three-year limited warranty for its MotorDrape™ DC systems and controls. BTX warrants its other systems and wvu/22uV motors and hardware accessories against defects in material and workmanship for a period of five years from date of shipment from BTX's Dallas base; however, pull chains and cords for roller shades are excluded. BTX controls and electric and electronic components carry a one-year warranty against defects in material and workmanship from date of shipment from BTX's Dallas base. BTX does not warrant cords and tapes for lift systems, nor customer's own materials, and BTX disclaims any written, oral or implied warranties for such materials. If any item to which a warranty applies proves to be defective during the specified warranty period under normal and proper use and provided the equipment or part has been properly stored, installed and maintained with due regard to any directives, instructions and operating procedures provided, BTX shall, upon presentation of proof of purchase, repair or replace the item at the sole option of BTX, F.O.B. Dallas. Application of the warranty will be determined by BTX technical staff after return of the item, its inspection and any necessary investigation. This warranty does not apply in case of defects resulting from faulty installation, misuse, misapplication, abuse, mishandling, shipping or failure to follow

instructions. This warranty does not cover any incidental, special or consequential damages, labor on location, service calls, reinstallation, or expenses involved in shipping, packing, and returning the goods. It also does not cover damages caused by fire, flood, or act of God. BTX warrants items repaired or replaced pursuant to the above warranty, under normal and proper use, storage, installation and maintenance, against defects in material and workmanship for a period of x days from date of start-up of such repaired or replaced item or the expiration of the original warranty, whichever is longer. Correction of non-conformities in the manner and for the period of time specified herein shall be purchaser's exclusive remedy and shall constitute fulfillment of all liabilities of BTX, whether in warranty, contract, negligence, tort, or otherwise with respect to the item delivered. In no event shall BTX be responsible for providing access to the allegedly defective item or for disassembly or reinstallation of such item or parts.

## 9. Disclaimer

THE FOREGOING EXPRESS WARRANTIES ARE EXCLUSIVE AND IN LIEU OF ALL OTHER WARRANTIES, WRITTEN, ORAL OR IMPLIED. ALL OTHER WARRANTIES, INCLUDING ANY WARRANTY OF MERCHANTABILITY OR FITNESS FOR A PARTICULAR PURPOSE, ARE HEREBY DISCLAIMED.

## 10. Limited Liability

BTX's liability for any and all claims, charges, expenses, damages, losses and injuries arising out of or relating to its performance or breach of any agreement of sale for goods and/or the manufacture, sale, delivery, resale, repair or use of any goods shall not exceed the purchase price of such goods, regardless whether the claim is based on contract, tort, negligence, statute, strict liability, willful or wanton conduct, warranty express or implied or otherwise. This shall be purchaser's sole and exclusive remedy against BTX other than the remedy provided for under the express BTX warranties. In no event shall BTX be liable for incidental, special, consequential or exemplary damages.

## 11. ARBITRATION

BTX and purchaser agree that this transaction involves interstate commerce and that at the option of btx, any dispute relating to it in any manner shall be submitted to binding arbitration before the American Arbitration Association and shall be governed by the federal arbitration act or, if that statute is inapplicable, any dispute shall be governed by the Texas Arbitration Act; however, no arbitrator may award punitive damages. Purchaser agrees TO PAY ALL COSTS INCURRED BY BTX, INCLUDING BUT NOT LIMITED TO COSTS OF ARBITRATION, COLLECTION, REASONABLE ATTORNEY'S FEES, EXPENSES AND ANY COURT COSTS.

## 12. Return

No goods may be returned without the express written approval of BTX and the receipt of an BTX RGA identification number. Goods approved for return must be returned in original packaging, freight prepaid, clearly marked with the BTX RGA identification number and be accompanied by a copy of the original invoice. Application of the warranty will be determined by BTX technical staff after return of the item, its inspection, and any necessary investigation. A restocking charge of 2% of invoice value will apply on all items accepted for return.

## 13. Liens and Security Interest

Purchaser will not permit to be created or to remain undischarged any lien, encumbrance or charge upon the goods supplied by BTX until BTX has received payment in full for such goods. If any liens, encumbrances or charges shall be filed against BTX goods prior to payment in full, purchaser shall discharge the liens, encumbrances or charges within ten days and reimburse BTX for expenses incurred in defending its security interest. Title to the goods shall remain with BTX until payment in full has been received.

## 14. Statute of Limitations

Any action against BTX shall be commenced within one year after the cause of action has arisen.

## 15. Choice of Law and Venue

The rights and duties of the parties hereunder and the construction and effect of these terms and conditions shall be governed by the laws of the State of Texas. Venue shall lie in Dallas, Texas, to the exclusion of any other jurisdiction.

16. This agreement supersedes any inconsistent or additional promises made by any employee, representative, agent or dealer of BTX.

17. If any part of this agreement is found invalid, the balance of the agreement remains enforceable.

***BTX***<sup>®</sup>

**BTX Window Automation, Inc.**  
**10763 Sanden Drive • Dallas, Texas 75238**  
**PH (214) 340-2800 • (800) 422-8839 • FX (214) 343-2252**  
**[www.btxinc.com](http://www.btxinc.com) • [btxwindow@btxinc.com](mailto:btxwindow@btxinc.com)**