

BTX[®]

5060 Sofia[™]



Installation Instructions for 5060 Sofia[™] Motorized Drapery System

Motorized Drapery 5060 Sofia[™]

Tools Required:

Power Screwdriver
w/Phillips bit

Screws & Anchors

Needle Nose Pliers

Wire Cutters

Flathead Screwdriver

Small Phillips

Small Flathead

Test Cable

Hacksaw (only used for
cutting down track)

Table of Contents

Installing the 5060 Sofia	3
Splicing the 5060 Sofia	4
Installing the 5060 Sofia Tandem System.	5
Limit Adjustment Instructions for 5060 Sofia	6-7
Basic Switch Control Wiring	8
Maintenance Instructions for 5060 Sofia.	8
Cutting Down the 5060 Sofia	
Cutting Down a Split-Draw System	9
Cutting Down a One-Way System	10
Warranty	11

Installing the 5060 Sofia™

Track Installation

The brackets supplied will accommodate either wall or ceiling mount applications. Due to the various building materials used in construction, BTX does not supply the fasteners. The Sofia system requires at least one bracket every 20". Use more brackets with heavier fabrics.

1. Mount bracket hardware to the ceiling (**Fig. 1**) or wall (**Fig. 2**), depending on your specific application.
NOTE: Make sure all screws are mounted into firm material with enough strength to hold track and drapery load. Do not overtighten screws on the clips or they will be impossible to rotate. Do not apply load to sheet rock or soft materials!!
2. Attach headrail to the brackets.
3. Check all clips and ensure that clips have been fully rotated and are pressed firmly against the headrail. On an inside mount, make sure to leave about an inch on the motor side for space to attach motor.
4. For spliced tracks, see next page.

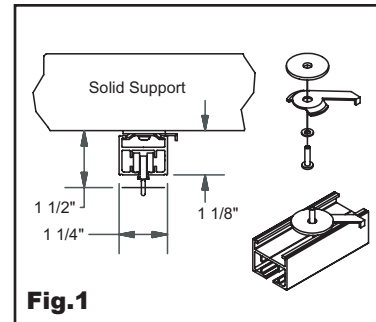

Fig. 1

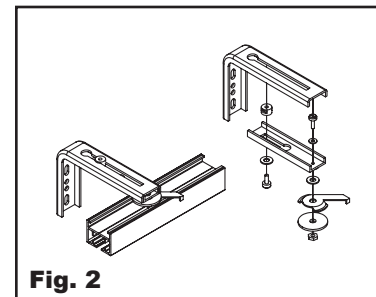

Fig. 2

Attach drapery motor to the track

1. Align blue dot on master carrier with blue dot on headrail.
2. Install motor, aligning blue dot on motor with blue dot on gear housing.
3. Rotate motor, aligning red dot on motor with red dot on gear housing. **Push motor locking clip (Fig. 3) into gear housing!**
4. Motor is properly installed when red dot on master carrier aligns with red dot on headrail.

Test the motor on the track before you hang the drapery. After the drapery is hung onto the headrail, the motor limits may have to be adjusted. For this, please refer to the BTX Limit Adjustment Instructions page.

1. Check that locking clip is secure.
2. Using your test cable, run the motor.

NOTE: For tandem systems, make sure the wiring harness is properly plugged in, i.e., appropriate plugs are in the drive and non-drive motors.

Attach system to controls

This will either be a MMC integrated control, plug in UCM, or a hardwire option.

For hardwire (**Fig. 4**), use the pigtail that is supplied by BTX. If using the plug-in option, just plug control into motor and then into a standard 110V outlet.

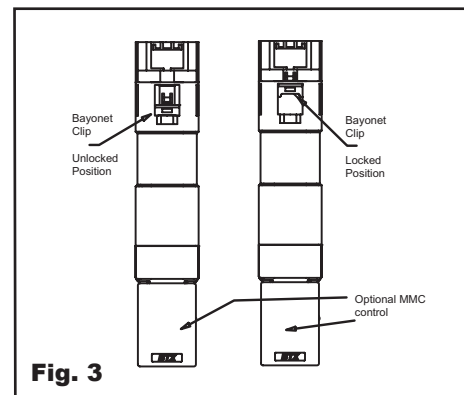

Fig. 3

Hardwired Example:

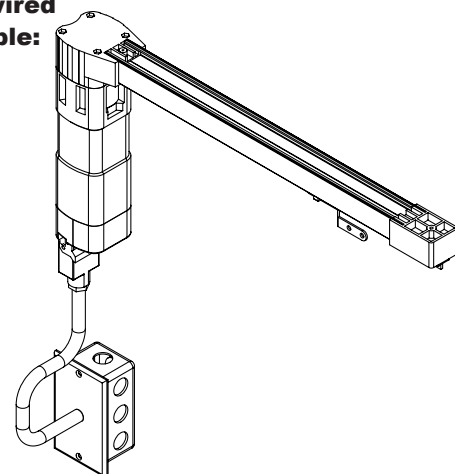
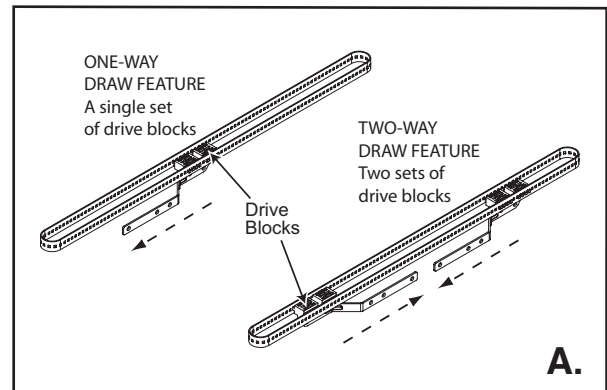

Fig. 4

Splicing the 5060 Sofia™

In order to decrease expenses for crating and freight in long drapery systems, the Sofia tracks are supplied in sections. This means that the fully manufactured tracks are partially disassembled at the factory after completion, limit setting and testing. Breaking down long, curved or complex units into smaller sizes makes them more manageable, and they can be quickly reconnected at the site. Shipping in smaller units also permits access through cramped installation areas.

1. The tracks are provided with an internal transportation belt. This belt is connected into a continuous loop by means of the master carrier assembly. In the disassembled tracks, the master carrier has been disconnected from its drive blocks and must be installed. (Fig. A)



2. Prior to working on the connection, place the track sections with the adjoining track ends approximately one foot apart.

3. Place the track splice into the track slot of both adjoining ends (Fig. B2). Slide the track ends together so that the tracks meet tightly. (If your track includes the heavy duty splice, you will slide the track ends together with the heavy duty splice going over both tracks. See Fig. B1) Make sure the ends of the track are square to each other. Insert short splicer screws and tighten. Ensure that screws do not extend into path of master carrier inside the headrail.

4. Check for alignment of headrail.

5. Make sure the ends of the track are square to each other. Insert short splicer screws and tighten. Ensure that screws do not extend into path of master carrier inside the headrail.

6. Move plastic drive blocks together with needle-nose pliers and insert metal master carrier into the slots of the blocks. Attach grey plastic safety clip over metal master carrier and between drive blocks. This locks the master into the blocks. **NOTE: A one-way draw track has one master carrier assembly. A two-way draw (or split-draw) has two carrier sets. For splicing, only one carrier set has been disassembled (Fig. C).**

7. Track is now ready for installation. Refer back to installation instructions. **Make sure you install a bracket on both sides of splice joint.**

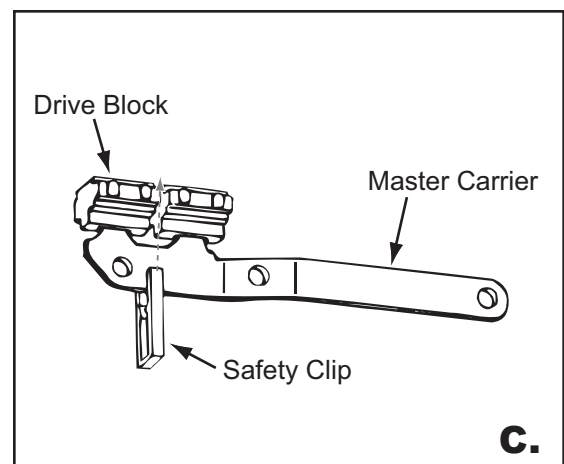
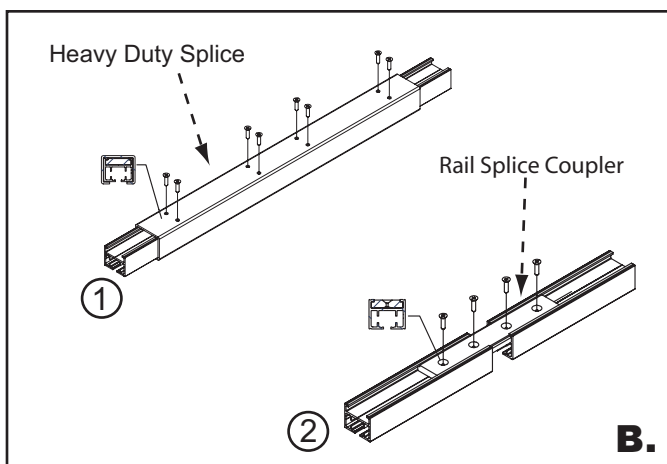

Installing Tandem Motors

If the system you have ordered has been supplied with tandem motors, a wiring harness has been supplied to control the tandem motors. The following instructions will guide you through the proper procedure for wiring the motors to the control. Read and follow the instructions before attempting to operate the motors.

1. Remove the wiring harness from the packaging and stretch it out to check for proper length, i.e., from motor to motor. The harness should stretch at least this distance.
2. Identify the plugs by checking the labels on each plug. One plug will be marked "Drive Motor;" the other will be marked "Non-Drive Motor." You will notice the wires from each plug running into a small black box where they form a junction. Do not remove this box! Exiting this box is a 4-conductor lead which is to be connected to the wiring coming from the control.
3. Identify the motors by checking the labels that are on the back of each motor. One motor will be marked with the label "Drive Motor;" the other will be marked "Non-Drive Motor." If the motor labels are not visible, you can identify each motor by looking at the clear windows on the motor. The "Drive Motor" will have the limit switch assembly inside. The "Non-Drive" will look empty.
4. Attach motors to track in same manner as single motor system. **NOTE: Tandem motors will be rotated on gears at the same time, and you will need a helper for this step.**
5. Plug the appropriate plugs into the corresponding motors. The 4-conductor lead from the J-Box should then be connected to your control wiring. **NOTE: Tandem motors are designed to be operated simultaneously only. Do not run either motor individually, as this will cause the motors to get out of sync. Operating motors under such conditions will damage the system and will void your warranty.**
6. After the system has been tested for proper operation by using your test cable, secure the wire harness to the mounting surface behind track, using the cable clamps provided.

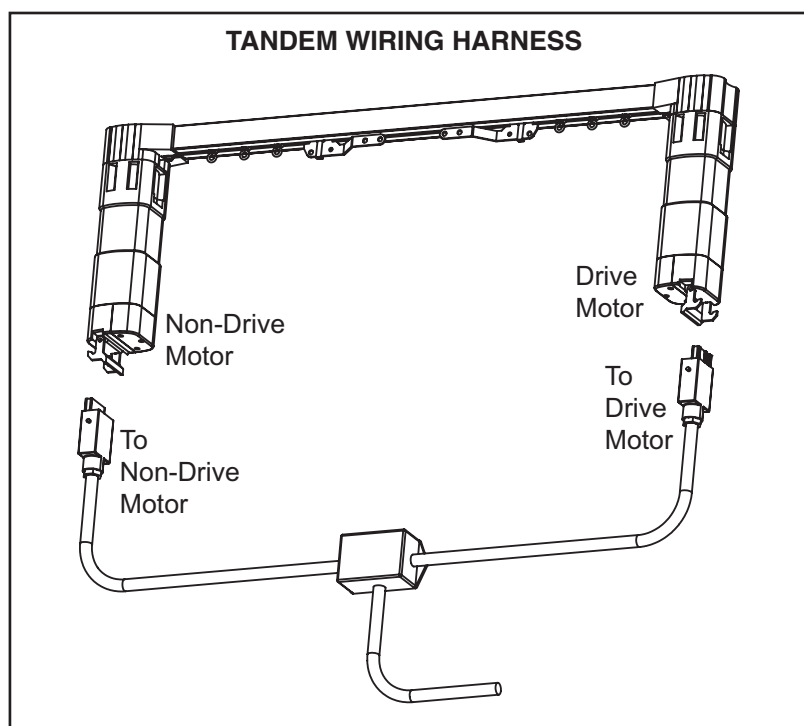

Limit Instructions

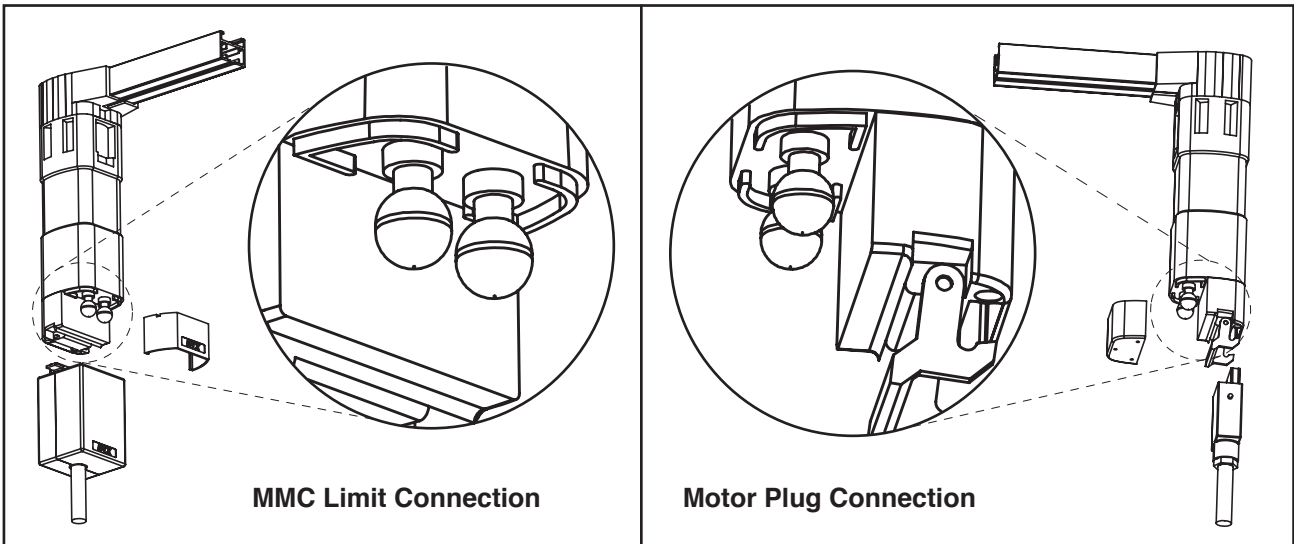

Adjustment

The following instructions are intended for use where a minor adjustment of the limits is required to accommodate the stacking requirements of the drapery, or where the original size of the system has been altered in the field per BTX instructions. For adjustments to be made, the motors must be running on the tracks, and a test cable should be used for this purpose.

- All tracks and motors have been numbered at the factory prior to shipping. **Verify that the motor and track numbers match before you attempt to set the limits.** If track and motor are mismatched, it could result in the limit buttons controlling the function opposite to those for which they are labeled.
- Install motor(s) on the appropriate track, and lock into place. If track is a tandem motor system, attach drive motor and non-drive motor to track and plug in Tandem wiring harness to motors. **Drive and non-drive motors, endcaps and plugs are labeled accordingly. Make certain they match up.**
- For Sofias that are either hardwire or with a plug-in control, locate limit buttons inside lid 1 by removing two Phillips head screws. Tandem motor systems have limits on drive motors only. Limit buttons are marked for the function they control, stack and close.
 - For Sofias that utilize the MMC integrated control, use a small flat tip to remove the limit cover. Limit buttons are marked for the function they control, stack and close.
- Run the track in the direction the adjustment needs to be made. At the same time, **observe the direction that the limit button to be adjusted is turning. Make sure to turn the corresponding button in that direction.**
 - Master is short of correct stop.**
With the switch powered in the correct position, push upon limit button to bump limit forward. The master will move forward as long as the limit button is turned open. Release once you get to the desired point on the track. You will hear a "click" from the micro switch as the limit button springs back into place. Run system in the opposite direction and then back to the direction you were adjusting to test accuracy of the limit. Repeat if necessary.
 - Master runs too far, need to stop it earlier.**
If you need to adjust the limit back, run motor and stop master where desired. Turn power off on the test cable. Push the limit button up and turn (see chart on next page) until micro switch "clicks."

Run motor to test using the chart on the following page.

Limit Instructions (cont'd)

The following instructions are intended for use in adjusting the limits and performing a test run.

Left Motor

Front = Close --- Turn the button COUNTER CLOCKWISE

Back = Stack --- Turn the button CLOCKWISE

Right Motor

Front = Stack --- Turn the button CLOCKWISE

Back = Close --- Turn the button COUNTER CLOCKWISE

5060 Sofia Limit Setting Instructions (for a new, previously unset motor)

Remove the limit cap from the motor by removing the two Phillips head screws and exposing the limit buttons.

Install the motor onto the track.

After motor has been rotated into place, make sure the locking clip has been completely pushed up into place.

Insert motor plug into motor from test cable.

New motors have both limits set, when power is turned on and neither direction will run. Test this.

Identify the two limit buttons:

Left motor

Front = Close

Back = Stack

Right motor

Front = Stack

Back = Close

Determine which direction the switch is in, either close or stack. With the power on (switch to an "on" position), push one of the limit buttons up and turn either clockwise or counter clockwise. If the motor does not run, let that button spring back down and then use the other limit button.

With both limits in the stopped position, adjust the desired limit by pushing the button up and turning the appropriate direction (see chart below). Turn the button only as far as necessary to open the limit and ensure that you see movement from the master. The master will move. Once the master is to the correct position, release the button and it will spring back in place and you will hear the micro switch "click." Turn the test cable to the off position. Run the track in the opposite direction for a few inches and stop. Now run the track back to test the accuracy of the limit. If master is short of correct stop, an adjustment is needed. With the switch powered in the correct position, open limit just to bump limit forward. If you need to adjust the limit back, stop master where desired and then turn button until micro switch "clicks." Run motor to test.

Repeat for the opposite direction.

Left motor

Front = Close --- Turn the button COUNTER CLOCKWISE

Back = Stack --- Turn the button CLOCKWISE

Right motor

Front = Stack --- Turn the button CLOCKWISE

Back = Close --- Turn the button COUNTER CLOCKWISE

Basic Switch Wiring

Illustrated here is the basic wiring diagram for the switch control option for the 5060 Sofia Motorized Drapery System. **Caution! Do not wire motors in parallel!**

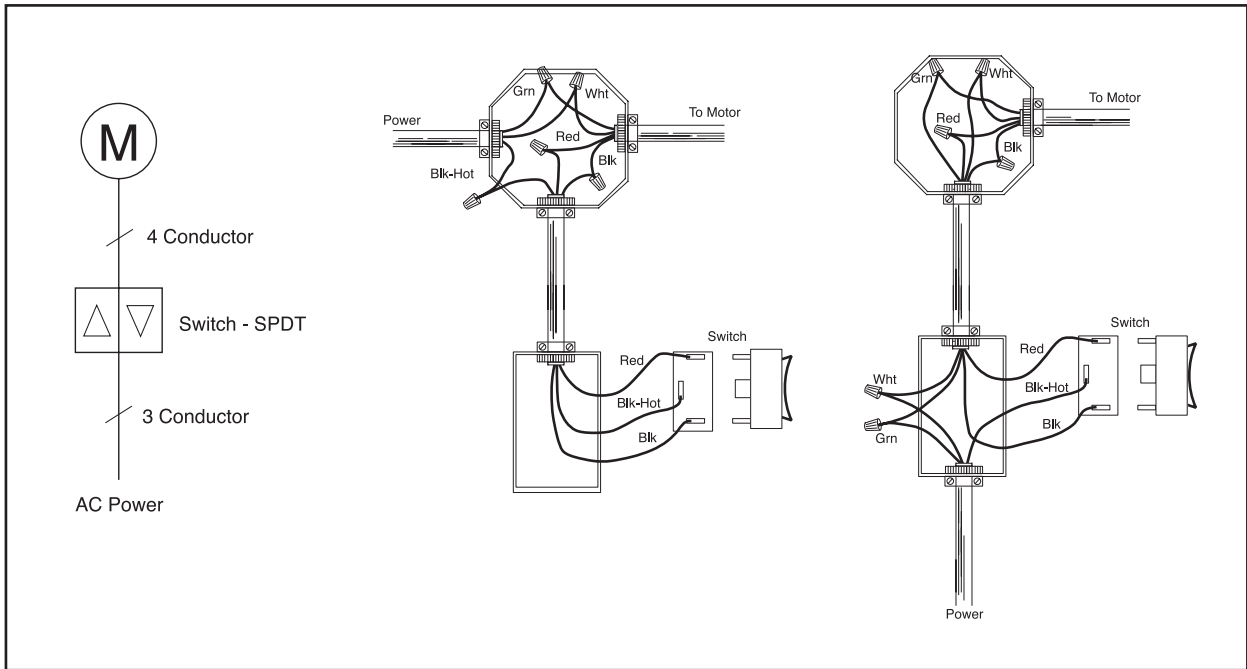

Maintenance Instructions

The 5060 Sofia Motorized Drapery Track System is basically designed for maintenance-free operation; however, inspections should be made at least once a year. At that time the following should be inspected:

1. The track should automatically shut off at the fully opened and fully closed position.
2. The drapery carriers should move freely by hand, with no jamming or dragging.
3. The end pulleys and splice locations should be visually inspected for residue such as belt shavings. Such residue may indicate improper alignment.
4. If lubrication is required, the belt, carrier wheels and end pulley should be lubricated generously with a high-quality clear silicon.

Cutting Down a Split Draw



NOTE: Please contact factory before you proceed with these steps.

1. Remove the motor if it is already installed.
2. Place the track on the floor so that the carriers are facing up.
3. There will be a “cager” at the drive-end that you will need to remove with a flat-head screwdriver before taking the carriers out. Be sure not to over turn the cager; otherwise, it will come apart and the pieces will fall into the track. Just loosen the screw. Remove all carriers.
4. Remove the gray plastic safety clip from the master overlap. You may have to use a small flat-head screwdriver to get the clip off the overlap.
5. Use needle-nose pliers to squeeze the drive blocks together (to relieve the tension) and pull the master overlaps out.
6. The belt will now be loose and you can remove the drive and non-drive gears from each end. Remove one drive block from the drive gear end and one drive block from the non-drive end. You will now be able to pull the belt through the gears and remove the belt from the track. (There will be two pieces of belt.)
7. Use a saw to cut off the amount of extrusion you wish to remove. For a spliced Sofia track you will need to cut off equal amounts from each end. This way you will keep the splice as centered on the track as possible. After cutting the track, use a razor knife to clean the edges of the aluminum where you made your cut. This will help to keep any metal shavings out of the gears once the track is reassembled. Make sure there are no shavings in the track.
8. Pull the transportation belt back through the track.
9. Using the drive blocks, push the blocks flush with the end of the extrusion (one block per side, per end). At the other side of the extrusion carefully measure and cut the belt 88.9 mm (**3.5"**) longer than the extrusion. The amount of belt cut off should be equal to twice the amount of extrusion cut off.
CAUTION: If you cut the belt short, you will have to contact the factory for more belt. Please measure carefully!!!
10. Feed the belt through the gears and attach the second drive block to the belts, and then slide the gears back together.
11. Reattach the master overlap using the pliers, and put the plastic safety clip back over the master overlap. Move the master, testing that the system has a good fluid motion back and forth on the track. This is a good time to spray the track with a high quality silicone spray before reinserting the carriers and screwing on the cager.
12. **Reset the limits on the motor. (See Limit Adjustment Section.)**

Cutting Down a One-Way Draw



NOTE: Please contact factory before you proceed with these steps.

1. Remove the motor if it is already installed.
2. Place the track on the floor so that the carriers are facing up.
3. There will be a “cager” at the drive-end that you will need to remove with a flat-head screwdriver before taking the carriers out. Be sure not to overturn the cager, as it will come apart and the pieces will fall into the track. Just loosen the screw. Remove all the carriers.
4. Remove the gray plastic safety clip from the master overlap. You may have to use a small flat-head screwdriver to get the clip off the overlap.
5. Use needle-nose pliers to squeeze the drive blocks together (to relieve the tension) and pull the master overlaps out.
6. The belt will now be loose and you can remove the drive and non-drive gears from each end. Remove one drive block from the drive gear end and one drive block from the non-drive end. You will now be able to pull the belt through the gears and remove the belt from the track.
7. Use a saw to cut off the amount of extrusion you wish to remove. For a spliced Sofia track you will need to cut off equal amounts from each end. This way you will keep the splice as centered on the track as possible. After cutting the track, use a razor knife to clean the edges of the aluminum where you made your cut. This will help to keep any metal shavings out of the gears once the track is reassembled. Make sure there are no shavings in the track.
8. Pull the transportation belt back through the track.
9. Using the drive blocks, push the blocks flush with the end of the extrusion. Now turn to the exposed belt end. Carefully measure and cut the belt 88.9 mm (3.5") longer than the extrusion. The amount of belt cut off should be equal to twice the amount of extrusion cut off. **CAUTION: If you cut the belt short, you will have to contact the factory for more belt. Please measure carefully!!!**
10. Feed the belt through the gears and attach the second drive block to the belts, and then slide the gears back together.
11. Using the pliers, re-attach the master overlap and put the plastic safety clip back over the master overlap. Move the master, testing that the system has a good fluid motion back and forth on the track. This is a good time to spray the track with a high-quality silicone spray before reinserting the carriers and screwing on the cager.
12. **Reset the limits on the motor. (See Limit Adjustment Section.)**

Warranty & Return Policy

1. Contract

All offers, quotes and sales by BTX Window Automation, Inc. (BTX) are subject to these Terms and Conditions of Sale. No other agreements have been made or will be valid unless expressly confirmed in writing by BTX.

2. ACCEPTANCE

BY TAKING DELIVERY OF BTX PRODUCTS, PURCHASER ASSENTS TO THE TERMS AND CONDITIONS STATED HEREIN, UNLESS OTHERWISE EXPRESSLY AGREED IN WRITING BY BTX. BTX HEREBY OBJECTS TO ANY DIFFERENT OR ADDITIONAL TERMS AND CONDITIONS WHICH MAY BE PROPOSED OR HAVE BEEN PROPOSED BY PURCHASER IN ANY PURCHASE ORDER FORMS OR OTHER DOCUMENTS. THE TERMS AND CONDITIONS STATED HEREIN SHALL PREVAIL OVER ANY DIFFERENT OR ADDITIONAL TERMS AND CONDITIONS PROPOSED BY PURCHASER AND SHALL APPLY TO THE SALE OR SHIPMENT OF ANY GOODS IN RESPONSE TO PURCHASER'S ORDER.

3. Prices and Delivery

All quoted prices are valid for a period of 60 days from the date of issue, unless otherwise agreed by BTX in writing. Prices on accepted orders remain firm for a period of four months from the date of order acceptance, provided final delivery occurs within that period. If delivery is to occur more than four months from the date of order acceptance, prices are subject to change in accordance with any changes in the published BTX price list which occur after the date of order acceptance. All prices quoted are FOB Dallas, excluding all freight, packaging and taxes. All delivery dates are approximate.

4. Payment Terms

(a) Open account payment terms may be established from time to time at the sole discretion of BTX, and are subject to credit approval in writing. Terms on open accounts are payment in full, net 30 days from date of invoice. Payment terms for single transactions and transactions other than on open account are net C.O.D. or prepay unless confirmed otherwise in writing by BTX.

(b) Amounts past due are subject to a finance charge of 1.5% per month to the legal limit, and the finance charge will apply without further prior notice. In case of purchaser's delinquency in payment or insolvency, BTX retains the right to halt or interrupt all further deliveries and service to the purchaser until all past due amounts have been paid, and to require payment in advance for orders not yet delivered, without any liability resulting for BTX. Purchaser expressly agrees to indemnify BTX and hold BTX harmless from all charges and liability which might arise in any manner from purchaser's nonpayment.

5. Inspection, Acceptance and Claims

All claims by purchaser against BTX for shortages must be made in writing to BTX within fourteen days from date of shipment from BTX's Dallas base or they are waived. Any claims for transport damage are the responsibility of the recipient and must therefore be filed with the carrier by the recipient.

6. Risk of Loss

Full risk of loss, damage or destruction of the goods shall pass to purchaser upon delivery of the goods to the carrier at the point of shipment or upon delivery at storage, whichever applies.

7. Force Majeure

If an order cannot be completed due to causes beyond BTX's control, BTX retains the right to

either cancel the uncompleted portion of the order or complete the order if and when this becomes possible. Purchaser shall not have the right to withhold payment on delivered goods and/or services, nor to unilaterally change the order or cancel same. Force majeure includes but is not limited to strikes, lock-outs, storms, floods and the like, terrorism, wars, revolutions, major equipment failures or fire damage at production facilities, etc.

8. Warranty

BTX extends a three-year limited warranty for its MotorDrape™ DC systems and controls. BTX warrants its other systems and 110/220V motors and hardware accessories against defects in material and workmanship for a period of five years from date of shipment from BTX's Dallas base; however, pull chains and cords for roller shades are excluded. BTX controls and electric and electronic components carry a one-year warranty against defects in material and workmanship from date of shipment from BTX's Dallas base. BTX does not warrant cords and tapes for lift systems, nor customer's own materials, and BTX disclaims any written, oral or implied warranties for such materials. If any item to which a warranty applies proves to be defective during the specified warranty period under normal and proper use and provided the equipment or part has been properly stored, installed and maintained with due regard to any directives, instructions and operating procedures provided, BTX shall, upon presentation of proof of purchase, repair or replace the item at the sole option of BTX, F.O.B. Dallas. Application of the warranty will be determined by BTX technical staff after return of the item, its inspection and any necessary investigation. This warranty does not apply in case of defects resulting from faulty installation, misuse, misapplication, abuse, mishandling, shipping or failure to follow instructions. This warranty does not cover any incidental, special or consequential damages, labor on location, service calls, reinstallation, or expenses involved in shipping, packing, and returning the goods. It also does not cover damages caused by fire, flood, or act of God. BTX warrants items repaired or replaced pursuant to the above warranty, under normal and proper use, storage, installation and maintenance, against defects in material and workmanship for a period of 30 days from date of start-up of such repaired or replaced item or the expiration of the original warranty, whichever is longer. Correction of nonconformities in the manner and for the period of time specified herein shall be purchaser's exclusive remedy and shall constitute fulfillment of all liabilities of BTX, whether in warranty, contract, negligence, tort, or otherwise with respect to the item delivered. In no event shall BTX be responsible for providing access to the allegedly defective item or for disassembly or reinstallation of such item or parts.

9. DISCLAIMER

THE FOREGOING EXPRESS WARRANTIES ARE EXCLUSIVE AND IN LIEU OF ALL OTHER WARRANTIES, WRITTEN, ORAL OR IMPLIED. ALL OTHER WARRANTIES, INCLUDING ANY WARRANTY OF MERCHANTABILITY OR FITNESS FOR A PARTICULAR PURPOSE, ARE HEREBY DISCLAIMED.

10. LIMITED LIABILITY

BTX'S LIABILITY FOR ANY AND ALL CLAIMS, CHARGES, EXPENSES, DAMAGES, LOSSES AND INJURIES ARISING OUT OF OR RELATING TO ITS PERFORMANCE OR BREACH OF ANY AGREEMENT OF SALE

FOR GOODS AND/OR THE MANUFACTURE, SALE, DELIVERY, RESALE, REPAIR OR USE OF ANY GOODS SHALL NOT EXCEED THE PURCHASE PRICE OF SUCH GOODS, REGARDLESS WHETHER THE CLAIM IS BASED ON CONTRACT, TORT, NEGLIGENCE, STATUTE, STRICT LIABILITY, WILLFUL OR WANTON CONDUCT, WARRANTY (EXPRESS OR IMPLIED), OR OTHERWISE. THIS SHALL BE PURCHASER'S SOLE AND EXCLUSIVE REMEDY AGAINST BTX OTHER THAN THE REMEDY PROVIDED FOR UNDER THE EXPRESS BTX WARRANTIES. IN NO EVENT SHALL BTX BE LIABLE FOR INCIDENTAL, SPECIAL, CONSEQUENTIAL OR EXEMPLARY DAMAGES.

11. ARBITRATION

BTX AND PURCHASER AGREE THAT THIS TRANSACTION INVOLVES INTERSTATE COMMERCE AND THAT AT THE OPTION OF BTX, ANY DISPUTE RELATING TO IT IN ANY MANNER SHALL BE SUBMITTED TO BINDING ARBITRATION BEFORE THE AMERICAN ARBITRATION ASSOCIATION AND SHALL BE GOVERNED BY THE FEDERAL ARBITRATION ACT OR, IF THAT STATUTE IS INAPPLICABLE, ANY DISPUTE SHALL BE GOVERNED BY THE TEXAS ARBITRATION ACT; HOWEVER, NO ARBITRATOR MAY AWARD PUNITIVE DAMAGES. PURCHASER AGREES TO PAY ALL COSTS INCURRED BY BTX, INCLUDING BUT NOT LIMITED TO COSTS OF ARBITRATION, COLLECTION, REASONABLE ATTORNEY'S FEES, EXPENSES AND ANY COURT COSTS.

12. Return

No goods may be returned without the express written approval of BTX and the receipt of an BTX RGA identification number. Goods approved for return must be returned in original packaging, freight prepaid, clearly marked with the BTX RGA identification number and be accompanied by a copy of the original invoice. Application of the warranty will be determined by BTX technical staff after return of the item, its inspection, and any necessary investigation. A restocking charge of 25% of invoice value will apply on all items accepted for return.

13. Liens and Security Interest

Purchaser will not permit to be created or to remain undischarged any lien, encumbrance or charge upon the goods supplied by BTX until BTX has received payment in full for such goods. If any liens, encumbrances or charges shall be filed against BTX goods prior to payment in full, purchaser shall discharge the liens, encumbrances or charges within ten days and reimburse BTX for expenses incurred in defending its security interest. Title to the goods shall remain with BTX until payment in full has been received.

14. Statute of Limitations

Any action against BTX shall be commenced within one year after the cause of action has arisen.

15. Choice of Law and Venue

The rights and duties of the parties hereunder and the construction and effect of these terms and conditions shall be governed by the laws of the State of Texas. Venue shall lie in Dallas, Texas, to the exclusion of any other jurisdiction.

16. This agreement supersedes any inconsistent or additional promises made by any employee, representative, agent or dealer of BTX.

17. If any part of this agreement is found invalid, the balance of the agreement remains enforceable.

WTY-030806

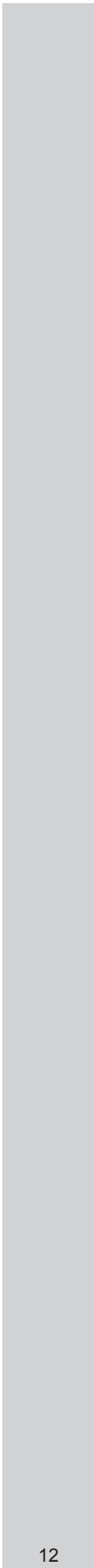

BTX Window Automation, Inc. • 10763 Sanden Dr. • Dallas, TX 75238
(214) 340-2800 • (800) 422-8839 • FAX (214) 343-2252 • www.btxinc.com