

BTX™

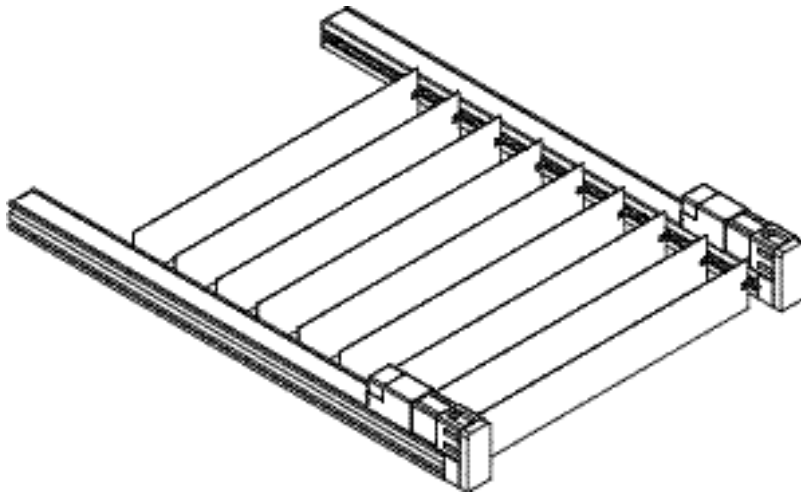

Installation Instructions for
Sky Control™ A2
Louvered Skylight

sky Control™ A2

Table of Contents

Tools Required:

Power Screwdriver

Extended bit for the
power screwdriver

Small Phillips

Small Flathead

Test Cable

Allen wrench set

Screws & Anchors

Also Perhaps:

Shims

Installing the A2

Ceiling Mount 3

Wall Mount 4

Installing Tandem Motors 5

Pocket Drawing 6

Limit Adjustment Instructions for A2 7

Maintenance Instructions for A2. 8

Basic Control Wiring

Switch 9

Infrared 10

Warranty 11

Installing the Sky Control™ A2

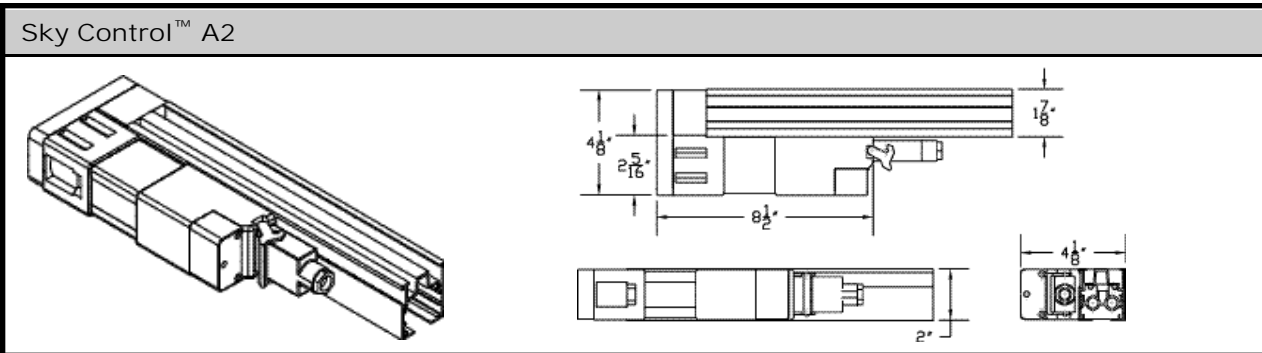

The A2 headrail may either utilize the ceiling mount screw channel, or it can use the wall mount brackets. Due to the various building materials used in construction, i.e. concrete, dry wall or wood, we do not supply the fasteners or screws.

Ceiling Mount

1. Secure headrail to the mounting surface by running fasteners through the screw channel located in the center of the rail. (See Fig.1) Fasteners should be located at each end and at 18" intervals throughout the rest of the rail. **IMPORTANT: Make sure the two tracks are perfectly parallel with each other. Not doing so could cause major damage to the system which would not be covered by the warranty.**
2. Limits are preset at factory using a test cable, run system prior to attaching the vanes to the carriers. (Go to "Installing Tandem Motors" on page 4). If system runs smoothly, proceed to #3; if not, call factory for assistance in adjusting the limits of the motor.
3. Attach one or two vanes to the lead carrier and test system again checking both the traversing and rotation functions. If the system runs smoothly, attach remaining vanes and test again.
4. Wire the system to the existing prewired pigtail (provided by BTX). If using the plug-in option, just plug control into motor and then into outlet.

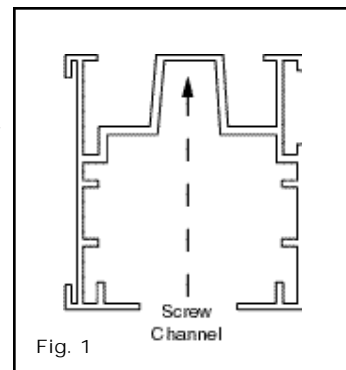

Installing the Sky Control™ A2

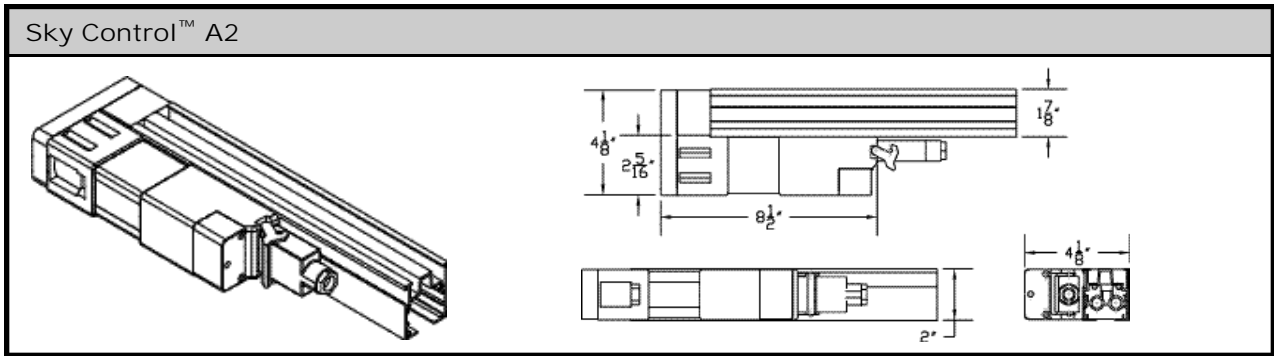

The A2 headrail may either utilize the ceiling mount screw channel, or it can use the wall mount brackets. Due to the various building materials used in construction, i.e. concrete, dry wall or wood, we do not supply the fasteners or screws.

Wall Mount

- Using the hardware provided, attach the headrail wall bracket mount to the L-bracket. The wall bracket mount can be easily moved down the headrail via the Allen screw located underneath the mount. (See Fig. 2) **IMPORTANT: Make sure the two tracks are perfectly parallel with each other. Not doing so could cause major damage to the system which would not be covered by the warranty.**
- Limits are preset at factory using a test cable, run system prior to attaching the vanes to the carriers. (Go to "Installing Tandem Motors" on page 4). If system runs smoothly, proceed to #3; if not, call factory for assistance in adjusting the limits of the motor.

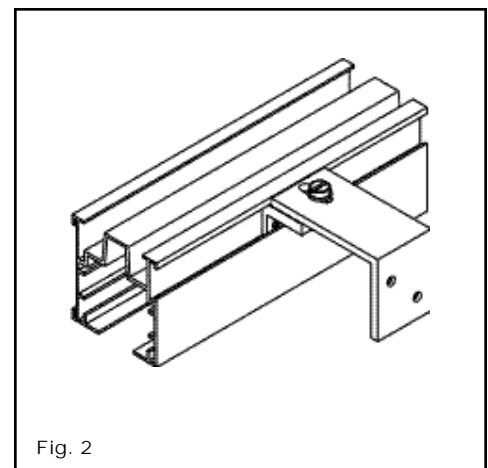
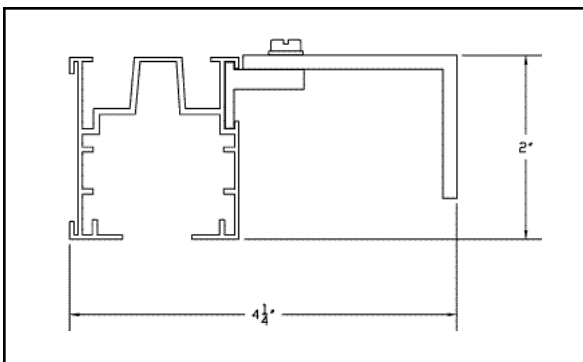

Fig. 2



- Attach one or two vanes to the lead carrier and test system again checking both the traversing and rotation functions. If the system runs smoothly, attach remaining vanes and test again.
- Wire the system to the existing prewired pigtail (provided by BTX). If using the plug-in option, just plug control into motor and then into outlet.

Installing Tandem Motors

The system you have ordered has been supplied with tandem motors. A wiring harness has been supplied to control the tandem motors. The following instructions will guide you through the proper procedure for wiring the motors to the control. Read and follow the instructions before attempting to operate the motors.

1. Remove the wiring harness from the packaging and stretch it out to check for proper length, i.e., from motor to motor. The harness should stretch at least this distance.
2. Identify the plugs by checking the labels on each plug. One plug will be marked "Drive Motor"; the other will be marked "Non-Drive Motor". You will notice the wires from each plug running into a small black box where they form a junction. Do not remove this box! Exiting this box is a 4-conductor lead which is to be connected to the wiring coming from the control.
3. Identify the motors by checking the labels that are on the back of each motor. One motor will be marked with the label "Drive Motor"; the other will be marked "Non-Drive Motor". If the motor labels are not visible, you can identify each motor by looking at the clear housing on the motor. The "Drive Motor" will have the limit switch assembly inside. The "Non-Drive" will look empty.
4. After the system has been tested for proper operation by using your test cable, secure the wire harness to the mounting surface, using the cable clamps provided.
5. The 4-conductor lead from the small J-Box can now be connected to your control wiring.

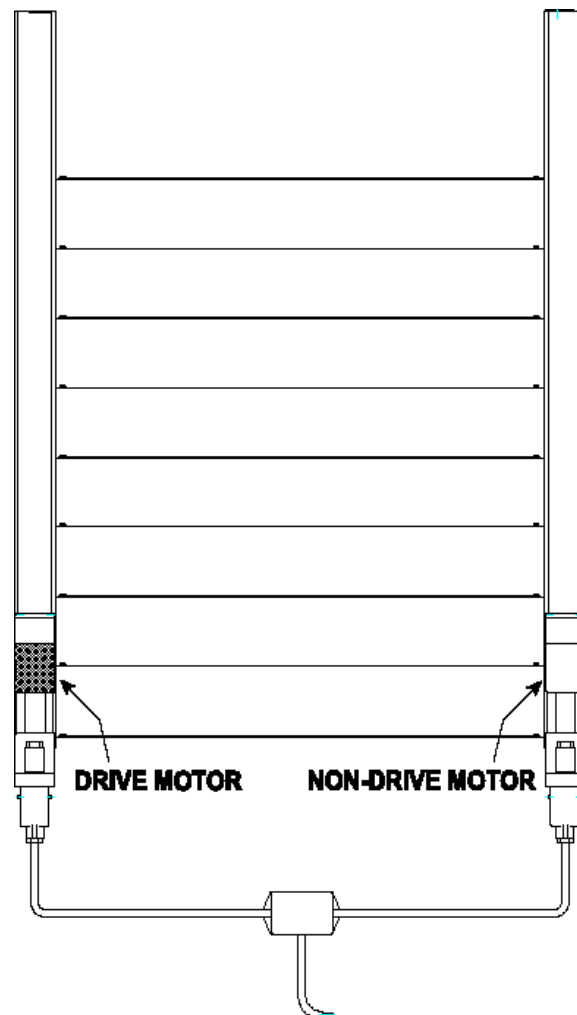

Pocket Drawing

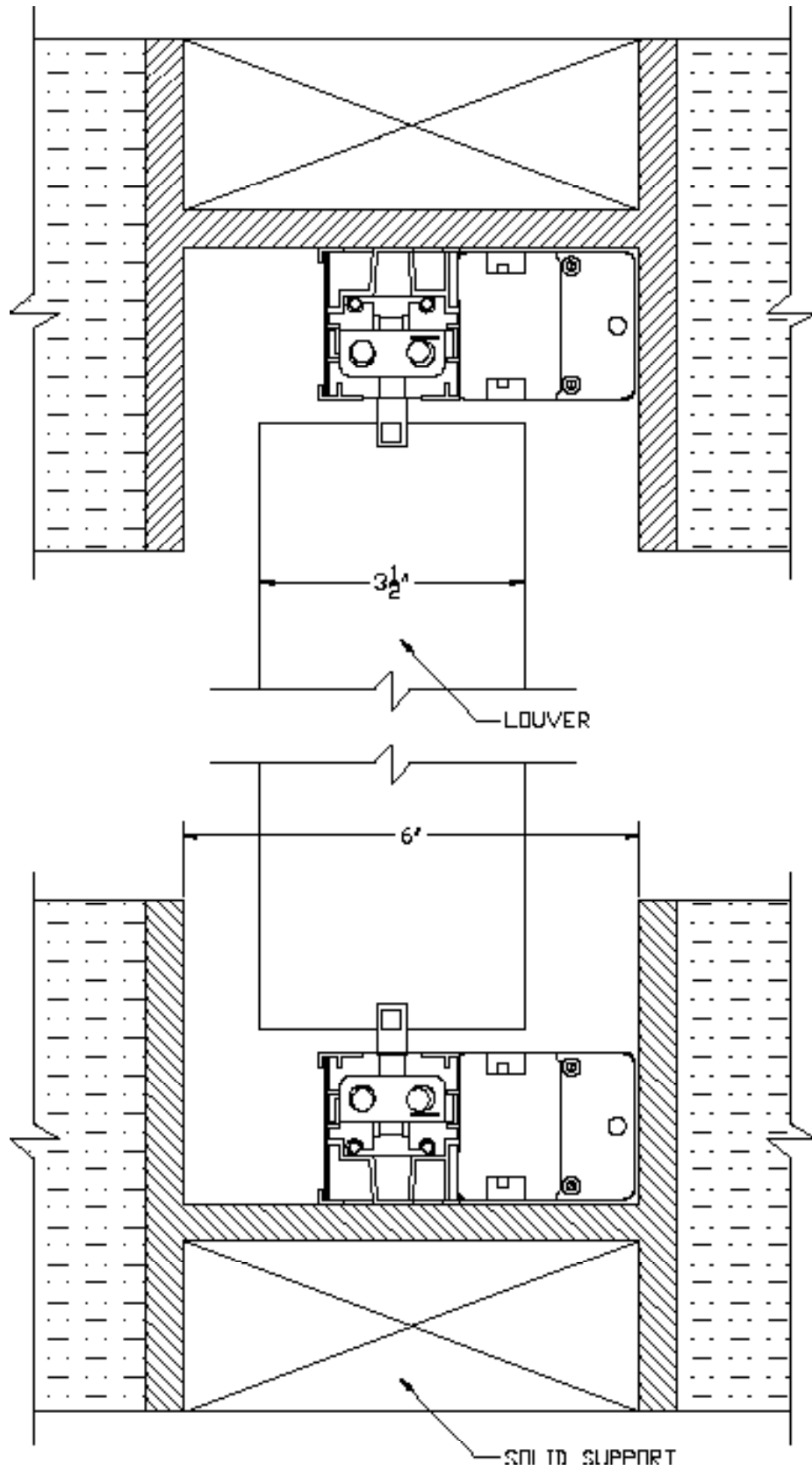

Limit Adjustment Instructions

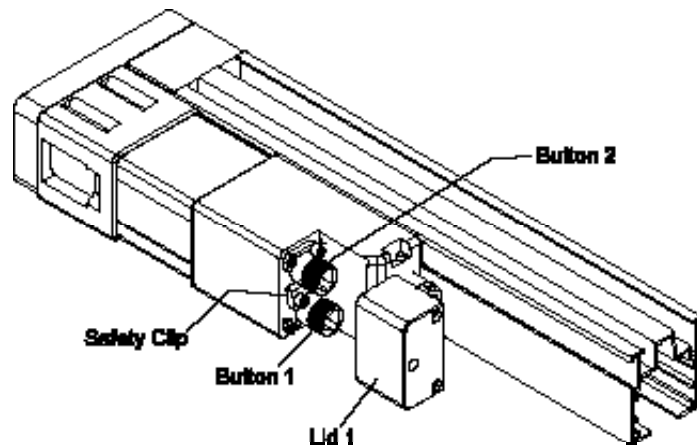

The following instructions are intended for minor adjustment of the limits. For adjustments to be made, the motors must be running on the tracks, and a test cable should be used for this purpose.

1. All tracks and motors have been numbered at the factory prior to shipping. Verify that the motor and track numbers match before you attempt to set the limits. If track and motor are mismatched, it could result in the limit buttons controlling the function opposite to those for which they are labeled.
2. If track is a tandem motor system, plug in tandem wiring harness to motors. Drive and non-drive motors, endcaps and plugs are labeled accordingly. Make certain they match up.
NOTE: When running a tandem motor system, power from the switch should be applied to the wiring harness supplied with the track not directly to the drive motor.
3. Locate limit buttons inside lid 1 by removing three Phillips head screws. Tandem motor systems have limits on drive motors only. Limit buttons are marked for the function they control stack and close.
4. Run the track in the direction the adjustment needs to be made. At the same time, observe the direction that the limit button to be adjusted is turning.
 - A. If the motor shuts off before reaching the intended location, push the safety clip to one side, push the limit knob in, and carefully turn it in the opposite direction. The motor should immediately begin to advance in the direction it was running before shutting off. When it reaches the correct stopping point, carefully pull the button out and lock it into place with the safety clip. Hand tighten a screw into safety clip to ensure limits will not adjust themselves. Test run to verify that the limit is set.
 - B. In the event that the motor is running past where it should shut off, shut it off manually with the switch at the desired stopping point. Push the safety clip to one side and push in the limit button to be adjusted. Carefully turn the button in the same direction it was turning before being shut off. Watch and listen for the limit switch to drop into the recessed portion of the cams. When the limit switch can be seen engaging or makes an audible clicking sound, carefully pull the button out and lock it into place with the safety clip. Hand tighten a screw into safety clip to ensure limits will not adjust themselves. Test run to verify that the limit is set.

Maintenance for Sky Control™ A2

Storage

Prior to installation, units should be stored in original packaging, in an area free from moisture and dust.

Installation

Upon installation the units should be tested for proper operation and any necessary adjustments made.

Operation

The units should be lubricated every 12 months after installation. A light to medium weight high quality silicon should be sprayed throughout the inside of the track from end to end. Both shafts and carrier wheels should be coated with a light film of spray as well. The motor gear can be lubricated by directing the spray into the location marked below. The internal parts of the motor have been built with a lifetime lubrication.

Basic Wiring - Switch

Switch Control Option

Illustrated here is the basic wiring diagram for a switch control option for the Sky Control™ A2.

Caution! Due to the risk of feedback voltage from the capacitor, do not connect motors in parallel!

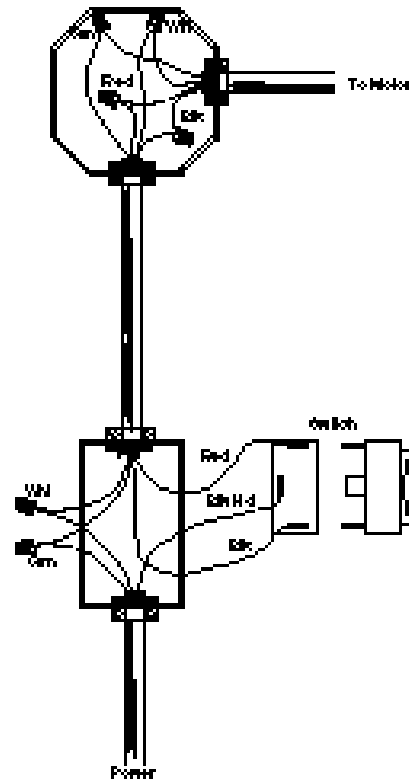
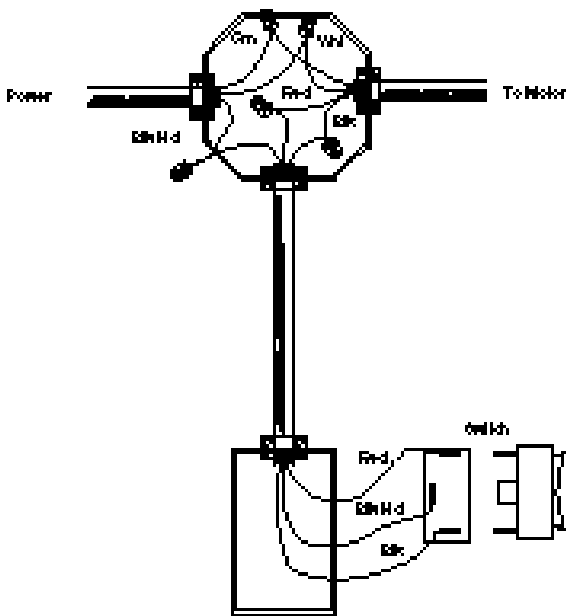
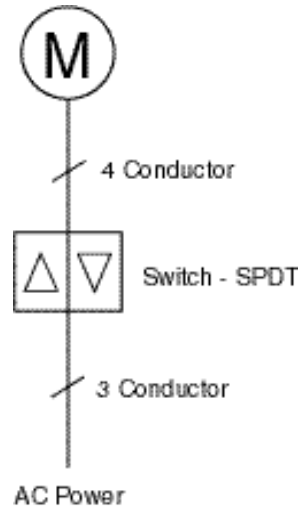

Basic Wiring - Infrared

Infrared Remote Control Option

Illustrated here is the basic wiring diagram for an infrared remote control option for the Sky Control™ A2.

Caution! Due to the risk of feedback voltage from the capacitor, do not connect motors in parallel!

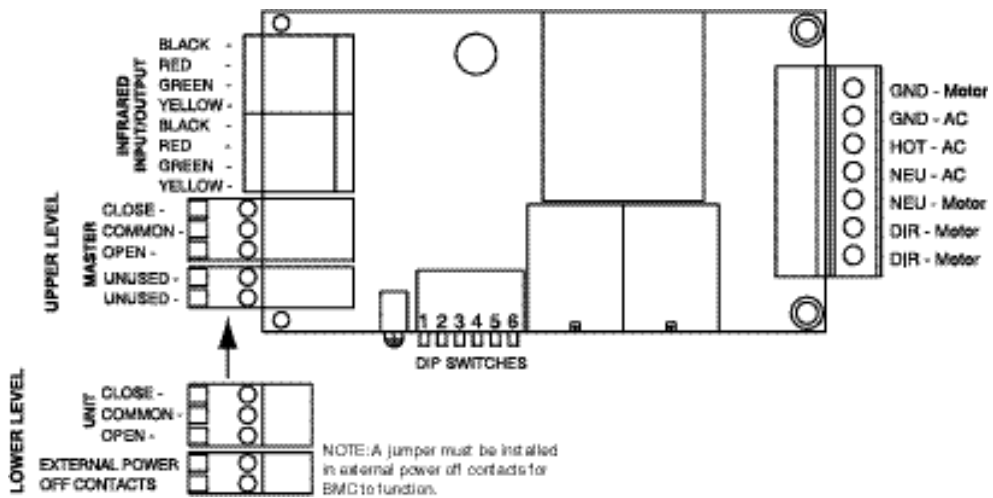
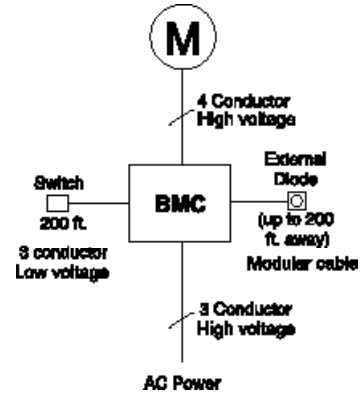

The BMC-12 uses a total of twelve different channels, corresponding to the twelve-channel remote handsender. To program your receiver using the easy dip switches, follow the chart to the right:

Manual Switch Style

Mode	1
Double Throw	On
Single Throw	Off

Motor Motion Setting

Mode	2
Full Motion	On
Jog/Latch	Off

Channel Setting

Dip Switches	3	4	5	6
Channel 1	Off	Off	Off	On
Channel 2	Off	Off	On	Off
Channel 3	Off	Off	On	On
Channel 4	Off	On	Off	Off
Channel 5	Off	On	Off	On
Channel 6	Off	On	On	Off
Channel 7	Off	On	On	On
Channel 8	On	Off	Off	Off
Channel 9	On	Off	Off	On
Channel 10	On	Off	On	Off
Channel 11	On	Off	On	On
Channel 12	On	On	Off	Off

Warranty & Return Policy

Motorized Systems

MOTORIZED SYSTEMS AND CONTROLS PURCHASED FROM BTX WINDOW AUTOMATION, INC.

1. All BTX motorized systems are warranted against defects in materials and workmanship for five years from the date of shipment from the Dallas factory of BTX. All BTX electrical and electronic controls are warranted against defects in materials and workmanship for two years from the date of shipment from the Dallas factory of BTX.
2. Should any failure to conform with this warranty appear during the specified period under normal and proper use, and provided that the motors, hardware or controls have been properly stored, installed and maintained with due regard to any directives, instructions and operating procedures provided by the manufacturer, BTX shall, upon presentation of proof of purchase, correct such nonconformity either by repair or by replacement of the nonconforming part, F.O.B. factory, at the option of BTX. Return of motors, hardware or controls pursuant to this paragraph shall be at purchaser's risk and expense.
3. BTX warrants motors, hardware and controls repaired or replaced pursuant to the foregoing warranties, under normal and proper use, storage, installation and maintenance, against defects in materials and workmanship for a period of 30 days from date of start-up of such repaired or replaced motors, hardware or controls or the expiration of the original warranty, whichever is longer.

The foregoing warranties do not cover defects resulting from misuse or failure to follow instructions. They also do not cover labor on location, service calls, reinstallation or expenses involved in shipping, packing or returning goods. Any alteration or repair other than by a factory authorized person will invalidate this warranty.

IN NO EVENT SHALL BTX BE LIABLE FOR ANY INDIRECT, INCIDENTAL, CONSEQUENTIAL OR OTHER DAMAGES IN CONNECTION WITH THIS PRODUCT. THIS DISCLAIMER APPLIES BOTH DURING AND AFTER THE PERIODS OF THESE WARRANTIES.

THE FOREGOING WARRANTIES ARE EXCLUSIVE AND IN LIEU OF ALL OTHER WARRANTIES, WHETHER WRITTEN, ORAL OR IMPLIED. ALL OTHER WARRANTIES, INCLUDING ANY WARRANTY OF MERCHANTABILITY OR FITNESS FOR A PARTICULAR PURPOSE, ARE HEREBY DISCLAIMED. Correction of nonconformities as provided above shall be purchaser's exclusive remedy and shall constitute fulfillment of all liabilities of BTX, whether in warranty, contract, negligence, tort or otherwise, with respect to the equipment or part delivered hereunder. In no event shall BTX be responsible for providing working access to the defect, including disassembly or reassembly of motors, hardware or controls.

Return Policy

BTX Window Automation products are customized, and as a rule, they cannot be returned. Any goods to be returned to the BTX factory for repair, credit or otherwise require prior authorization and must be clearly marked with the RGA (Return Goods Authorization) number issued by the BTX customer service department. No returned goods will be accepted unless clearly marked with an RGA number. Any return shipment to BTX must be freight prepaid. All shipments from the BTX factory will be made F.O.B., freight collect, best way, unless arranged otherwise. Final acceptance of returned goods is subject to factory inspection. Restocking charges will apply.

